

PRICE \$1.00



**Assembling  
and Using Your...**

# **Heathkit**

**VISUAL-AURAL  
SIGNAL TRACER**

**MODEL T-4**

**HEATH COMPANY**

*A Subsidiary of Daystrom Inc.*

**BENTON HARBOR, MICHIGAN**

# STANDARD COLOR CODE — RESISTORS AND CAPACITORS

Scan by mbravoc@wanadoo.es

AXIAL LEAD RESISTOR	INSULATED UNINSULATED Color	FIRST RING BODY COLOR First Figure	SECOND RING END COLOR Second Figure	THIRD RING DOT COLOR Multiplier	DISC CERAMIC RMA CODE
	BROWN — Insulated BLACK — Non-insulated	BLACK 0 BROWN 1 RED 2 ORANGE 3 YELLOW 4 GREEN 5 BLUE 6 VIOLET 7 GRAY 8 WHITE 9	0 1 2 3 4 5 6 7 8 9	None 0 00 ,000 0,000 00,000 000,000 0,000,000 00,000,000 000,000,000	

<b>RADIAL LEAD DOT RESISTOR</b> 	<b>5-DOT RADIAL LEAD CERAMIC CAPACITOR</b> 	<b>EXTENDED RANGE TC CERAMIC HICAP</b> 
<b>RADIAL LEAD (BAND) RESISTOR</b> 	<b>BY-PASS COUPLING CERAMIC CAPACITOR</b> 	<b>AXIAL LEAD CERAMIC CAPACITOR</b> 

The standard color code provides all necessary information required to properly identify color coded resistors and capacitors. Refer to the color code for numerical values and the zeroes or multipliers assigned to the colors used. A fourth color band on resistors determines tolerance rating as follows: Gold = 5%, silver = 10%. Absence of the fourth band indicates a 20% tolerance rating.

The physical size of carbon resistors is determined by their wattage rating. Carbon resistors most commonly used in Heathkits are 1/2 watt. Higher wattage rated resistors when specified are progressively larger in physical size. Small wire wound resistors 1/2 watt, 1 or 2 watt may be color coded but the first band will be double width.

## MOLDED MICA TYPE CAPACITORS

<b>CURRENT STANDARD CODE</b> 	<b>RMA 3-DOT (OBSOLETE) RATED 500 W.V.D.C. 20% TOL.</b> 	<b>BUTTON SILVER MICA CAPACITOR</b> 
<b>RMA (5-DOT OBSOLETE CODE)</b> 	<b>RMA 6-DOT (OBSOLETE)</b> 	<b>RMA 4-DOT (OBSOLETE)</b> 

## MOLDED PAPER TYPE CAPACITORS

<b>TUBULAR CAPACITOR</b> <p>Normally stamped for value</p> <p>A 2 digit voltage rating indicates more than 900 V. Add 2 zeros to end of 2 digit number.</p>	<b>MOLDED FLAT CAPACITOR</b> Commercial Code 	<b>JAN. CODE CAPACITOR</b> Silver 
--	---	--

The tolerance rating of capacitors is determined by the color code. For example: red = 2%, green = 5%, etc. The voltage rating of capacitors is obtained by multiplying the color value by 100. For example: orange = 3 × 100 or 300 volts. Blue = 6 × 100 or 600 volts.

In the design of Heathkits, the temperature coefficient of ceramic or mica capacitors is not generally a critical factor and therefore Heathkit manuals avoid reference to temperature coefficient specifications.

# ASSEMBLY AND OPERATION OF THE HEATHKIT VISUAL-AURAL SIGNAL TRACER MODEL T-4



## SPECIFICATIONS

Power Supply.....	Transformer operated.
Power Requirements.....	117 volts AC 50-60 cycle 25 watts.
Tube Complement.....	V1 12AX7 high gain dual triode, input cascade amplifier. V2 12CA5 beam power output tube. V3 1629 electron beam visual indicator.
Speaker.....	3 1/2" permanent magnet.
Probe and Test Leads.....	4' input lead for RF and audio w/switch in probe body. Two 3' panel test leads with alligator clips.
Dimensions.....	4 1/2" wide x 7 1/2" high x 4" deep.
Net Weight.....	4 lbs.
Shipping Weight.....	5 lbs.



## INTRODUCTION

The Heathkit Visual-Aural Signal Tracer Model T-4 is a compact, service-designed instrument incorporating many features that meet the everyday needs of the service technician. Some of the features and applications are listed below:

- High gain position for direct signal tracing in RF or IF circuits.
- High gain position for signal tracing in audio circuits.
- Convenient RF or audio switch in probe body.
- Tracer may be used for AM, FM, and TV circuit exploration.
- Visual signal indicator.
- Noise locator circuit.
- Utility amplifier for checking record changers, tuners, etc.
- Useful for checking microphones, musical instruments, pick-ups, and speakers.
- Substitution speaker and output transformer.
- Output level indicator.

## CIRCUIT DESCRIPTION

The Heathkit Signal Tracer Model T-4 is a transformer operated, quality instrument, consisting primarily of a high-gain audio amplifier. A built-in 3 1/2" speaker is provided for sound and an electron ray tube permits visual observation of the output level. Additional features are RF and audio inputs in one convenient probe, noise locator circuit, and substitution speaker, and output transformer.

Observing the schematic it can be seen that the RF-audio switch S2, mounted directly in the shielded probe body, switches condenser C1 and a crystal diode in or out of the circuit for RF or audio applications. Condenser C1 isolates the crystal diode to prevent any voltage damage.

The Noise Switch S3, connects B+ to the probe lead through resistor R14 to provide the noise locator circuit. The switch S2 in the probe must be in the audio position for this function.

Signals from the probe are coupled through condenser C2 to the gain-control R1 and in turn through condenser C3 to the input grid of V1. Condenser C2 and C3 prevent noisy operation of the gain-control.

The tube V1, 12AX7, is a high-gain dual triode with the plate of section A coupled through condenser C4 to the grid of section B.

The condenser C5 couples V1 (B), to the grid of V2, 12CA5 beam power output tube. The primary of the output transformer is center tapped and all three primary leads are brought out to terminals on the front panel. The power switch S1-B in the off position disconnects the B+ so the transformer may be used as a substitute output transformer.

The secondary leads are connected to the speaker voice coil panel terminals, and one side may be disconnected with the speaker switch S4 when the speaker is used as a substitute.

Resistor R9 and condenser C6 couple a small amount of the output signal to the grid of V3, 1629 eye tube.

The T-4 Signal Tracer is transformer operated, and uses a 50 ma selenium rectifier in a half wave circuit. The transformer also supplies 12.6 volts AC for the tube filaments.

## CONSTRUCTION NOTES

This manual is supplied to assist you in every way to complete the instrument with the least possible chance for error. We suggest that you take a few minutes now and read the entire manual through before any work is started. This will enable you to proceed with the work much faster when construction is started. We suggest that you retain the manual in your files for future reference, both in the use of the instrument and for its maintenance.

**UNPACK THE KIT CAREFULLY AND CHECK EACH PART AGAINST THE PARTS LIST.** In so doing, you will become acquainted with each part. Refer to the charts and other information shown on the inside covers of the manual to help you identify any parts about which there may be a question. If some shortage is found in checking the parts, please notify us promptly and return the inspection slip with your letter to us. Hardware items are counted by weight and if a few are missing, please obtain them locally if at all possible.

Resistors and controls generally have a tolerance rating of  $\pm 20\%$  unless otherwise stated in the parts list. Therefore a 100 K $\Omega$  resistor may test anywhere from 80 K $\Omega$  to 120 K $\Omega$ . (The letter K is commonly used to designate a multiplier of 1000.) Tolerances on condensers are generally even greater. Limits of +100% and -50% are common for electrolytic condensers. The parts furnished with your Heathkit have been specified so as to not adversely affect the operation of the finished instrument.

In order to expedite delivery to you, we are occasionally forced to make minor substitutions in parts. Such substitutions are carefully checked before they are approved and the parts supplied will work satisfactorily. By checking the parts list for resistors, for example, you may find that a 120 K $\Omega$  resistor has been supplied in place of a 100 K $\Omega$  as shown in the parts list. These changes are self-evident and are mentioned here only to prevent confusion in checking the contents of your kit.

The Model T-4 Signal Tracer is not difficult to construct but it is extremely important that particular emphasis be placed on the desirability of following parts placement and wiring dress as shown in the manual. This is important in order that the operation of the Signal Tracer be hum free and that a motor boating condition is not induced. The wiring dress and parts layout in the manual has been proven thoroughly satisfactory through the construction of a series of laboratory models. While the arrangement shown is probably not the only satisfactory layout, it is the result of considerable experimentation and trial. If followed carefully, it will result in a stable instrument operating at a high degree of accuracy and dependability.

We suggest you do the following before work is started:

1. Attach the large fold-in pictorials to the wall above your work bench.
2. Go through the entire assembly and wiring instructions. This is an excellent time to read the entire construction section through and familiarize yourself with the procedure.
3. Lay out all parts so that they are readily available. Refer to the general information inside the front and back covers of this manual to help you identify components.

Most kit builders find it helpful to separate the various parts into convenient categories. Muffin tins or molded egg cartons make convenient trays for small parts. Resistors and capacitors may be placed in the edge of a piece of corrugated cardboard until they are needed. Values can be written on the cardboard next to each component. The illustration shows one method that may be used.

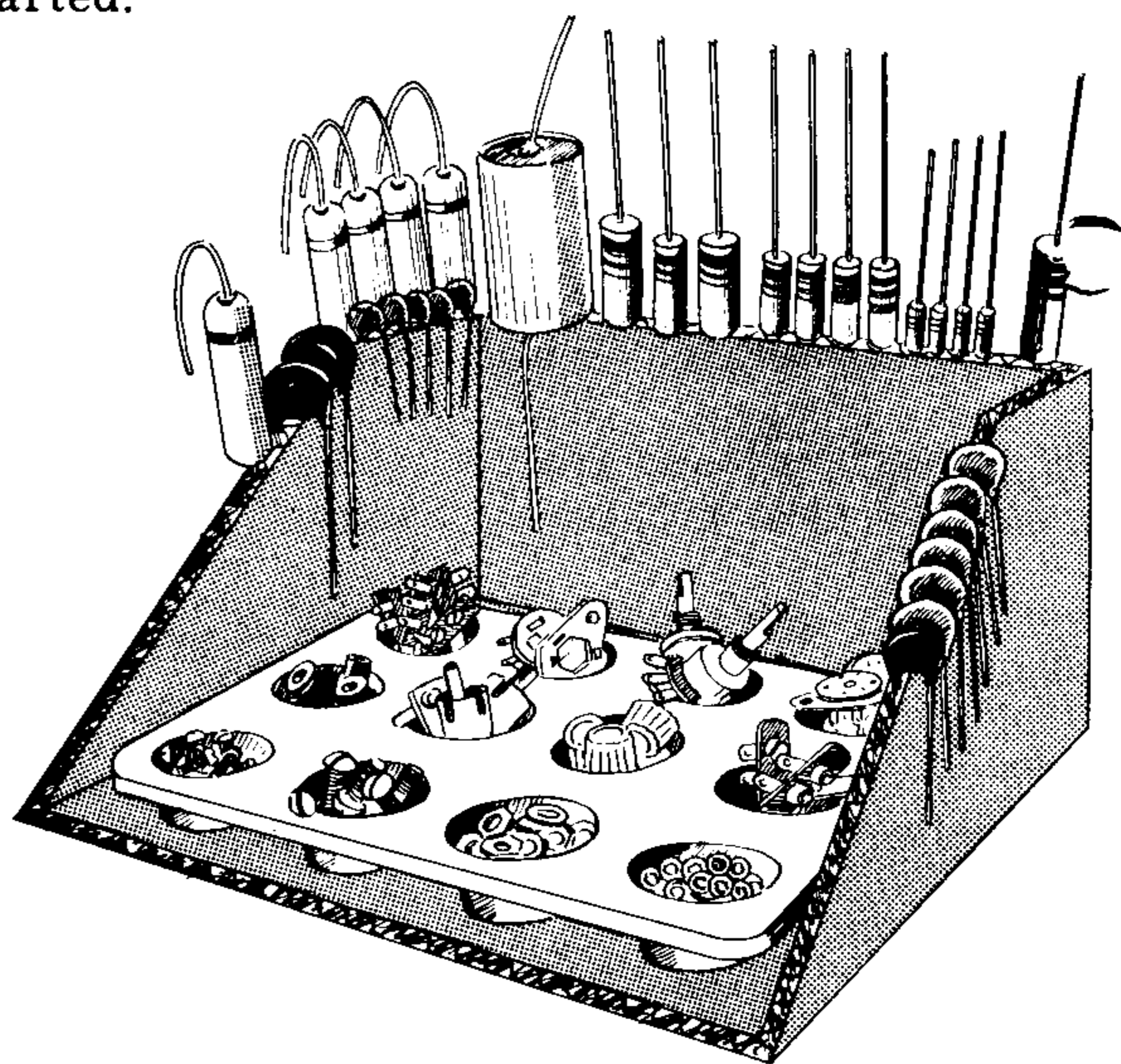

Leads on resistors, capacitors and transformers are generally much longer than they need to be to make the indicated connections. In these cases, the excess leads should be cut off before the part is added to the chassis. In general, the leads should be just long enough to reach their terminating points. Not only does this make the wiring much neater but in many instances, the excessively long leads will actually interfere with proper operation of the instrument.

Space has been provided for you to check off each operation as it is completed. This is particularly important in wiring and it may prevent omissions or errors, especially where your work is interrupted frequently as the wiring progresses. Some kit builders have also found it helpful to mark each lead in colored pencil on the pictorial as it is added.

Unless otherwise indicated, all wire used is insulated. Wherever there is a possibility of the bare leads on resistors and capacitors shorting to other parts or to chassis, the leads should be covered with insulated sleeving. This is indicated in the instructions by the phrase "use sleeving." Bare wire is used where the lead lengths are short and the possibility of short circuits are non-existent.

<p>NOTE: ALL GUARANTEES ARE VOIDED AND WE WILL NOT REPAIR OR SERVICE INSTRUMENTS IN WHICH ACID CORE SOLDER OR PASTE FLUXES HAVE BEEN USED. WHEN IN DOUBT ABOUT SOLDER, IT IS RECOMMENDED THAT A NEW ROLL PLAINLY MARKED "ROSIN CORE RADIO SOLDER" BE PURCHASED.</p>
---

#### PROPER SOLDERING PROCEDURE

Only a small percentage of Heathkit purchasers find it necessary to return an instrument for factory service. Of these, by far the largest proportion function improperly due to poor or improper soldering.

Correct soldering technique is extremely important. Good solder joints are essential if the performance engineered into the kit is to be fully realized. If you are a beginner with no experience in soldering, a half-hour's practice with odd lengths of wire and a tube socket will be a worthwhile investment.

High quality solder of the proper grade is most important. There are several different brands of solder on the market, each clearly marked "Rosin Core Radio Solder." Such solders consist of an alloy of tin and lead, usually in the proportion of 50:50. Minor variations exist in the mixture such as 40:60, 45:55, etc. with the first figure indicating the tin content. Radio solders are formed with one or more tubular holes through the center. These holes are filled with a rosin compound which acts as a flux or cleaning agent during the soldering operation.

NO SEPARATE FLUX OR PASTE OF ANY KIND SHOULD BE USED. We specifically caution against the use of so-called "non-corrosive" pastes. Such compounds, although not corrosive at room temperatures, will form residues when heated. The residue is deposited on surrounding surfaces and attracts moisture. The resulting compound is not only corrosive but actually destroys the insulation value of non-conductors. Dust and dirt will tend to accumulate on these "bridges" and eventually will create erratic or degraded performance of the instrument.

If terminals are bright and clean and wires free of wax, frayed insulation and other foreign substances, no difficulty will be experienced in soldering. Crimp or otherwise secure the wire (or wires) to the terminal, so a good joint is made without relying on solder for physical strength.

To make a good solder joint, the clean tip of the soldering iron should be placed against the joint to be soldered so that the terminal is heated sufficiently to melt solder. The solder is then placed against both the terminal and the tip of the iron and will immediately flow out over the joint. Refer to sketches on page 6 and 7. Use only enough solder to cover wires at the junction; it is not necessary to fill the entire hole in the terminal with solder. Excess solder may flow into tube socket contacts, ruining the socket, or it may creep into switch contacts and destroy their spring action. Position the work so that gravity tends to keep the solder where you want it.

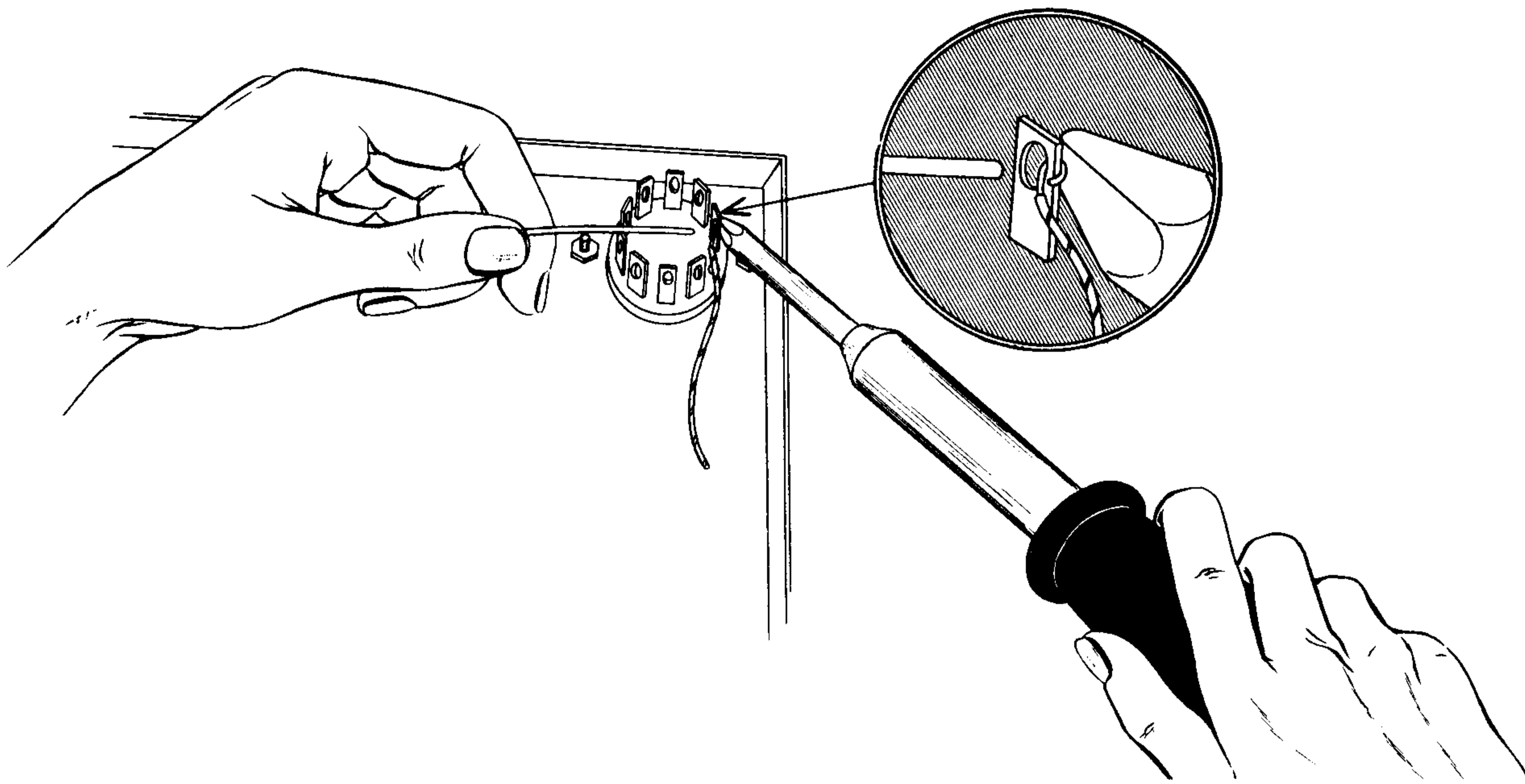

A poor solder joint will usually be indicated by its appearance. The solder will stand up in a blob on top of the connection, with no evidence of flowing out caused by actual "wetting" of the contact. A crystalline or grainy texture on the solder surface, caused by movement of the joint before it solidified is another evidence of a "cold" connection. In either event, reheat the joint until the solder flows smoothly over the entire junction, cooling to a smooth, bright appearance. Photographs in the adjoining picture clearly indicate these two characteristics.

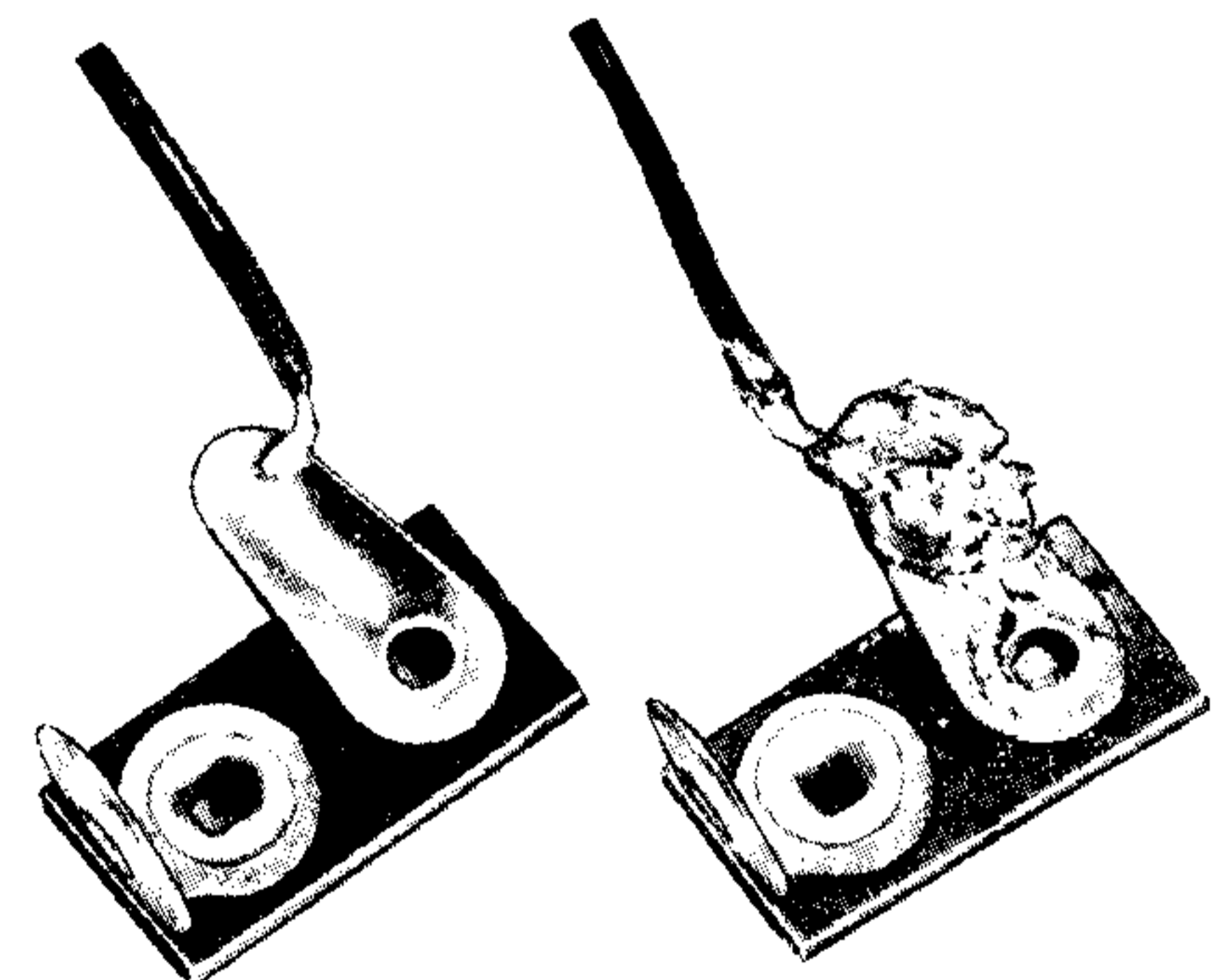

A good, clean, well-tinned soldering iron is also important to obtain consistently perfect connections. For most wiring, a 30 to 100 watt iron, or the equivalent in a soldering gun, is very satisfactory. Smaller irons generally will not heat the connections enough to flow the solder smoothly over the joint and are recommended only for light work, such as on etched circuit boards, etc. Keep the iron tip clean and bright. A pad of steel wool may be used to wipe the tip occasionally during use.

## HOW TO MAKE PROPER SOLDER CONNECTION

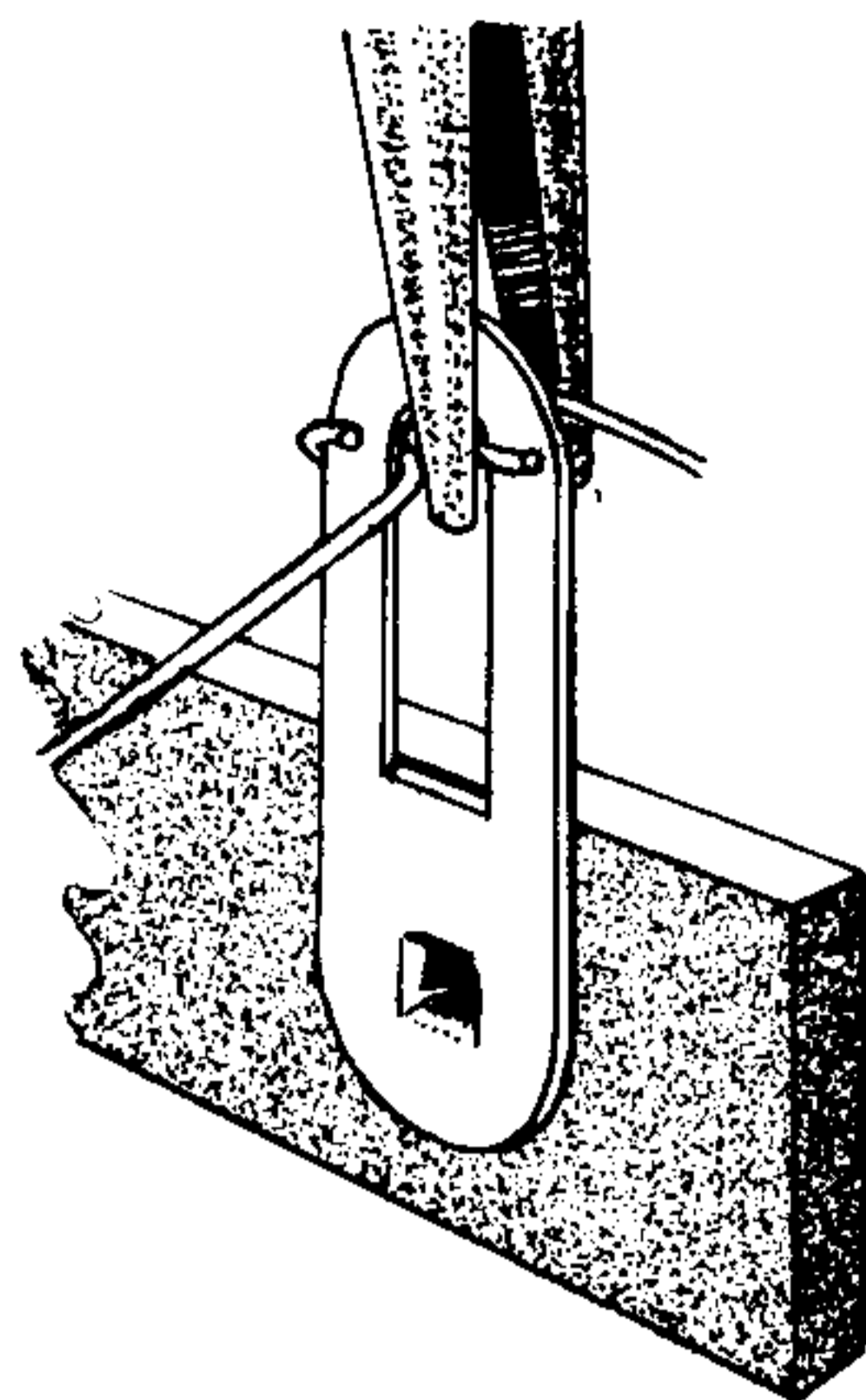

CRIMP WIRES

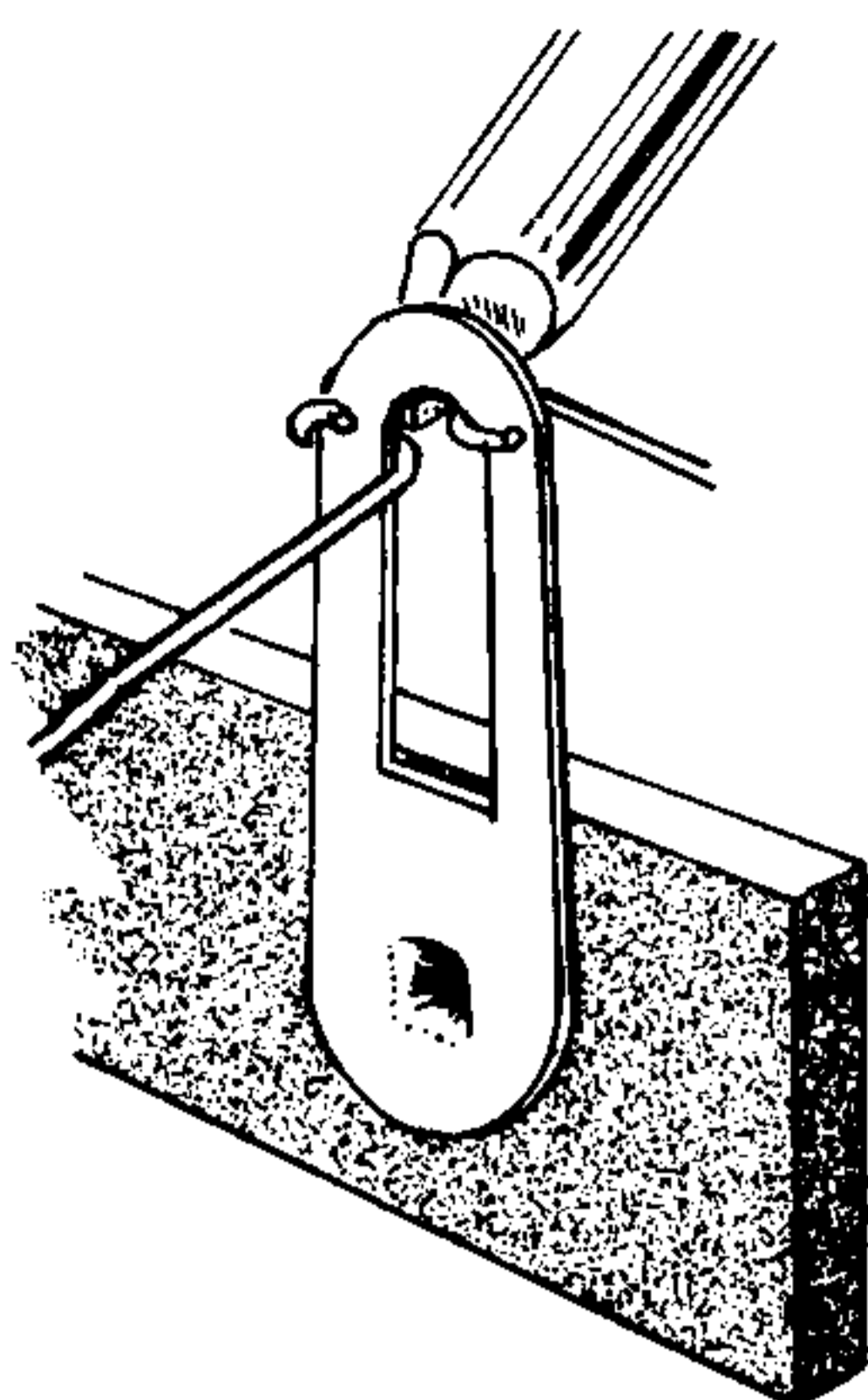

HEAT CONNECTION

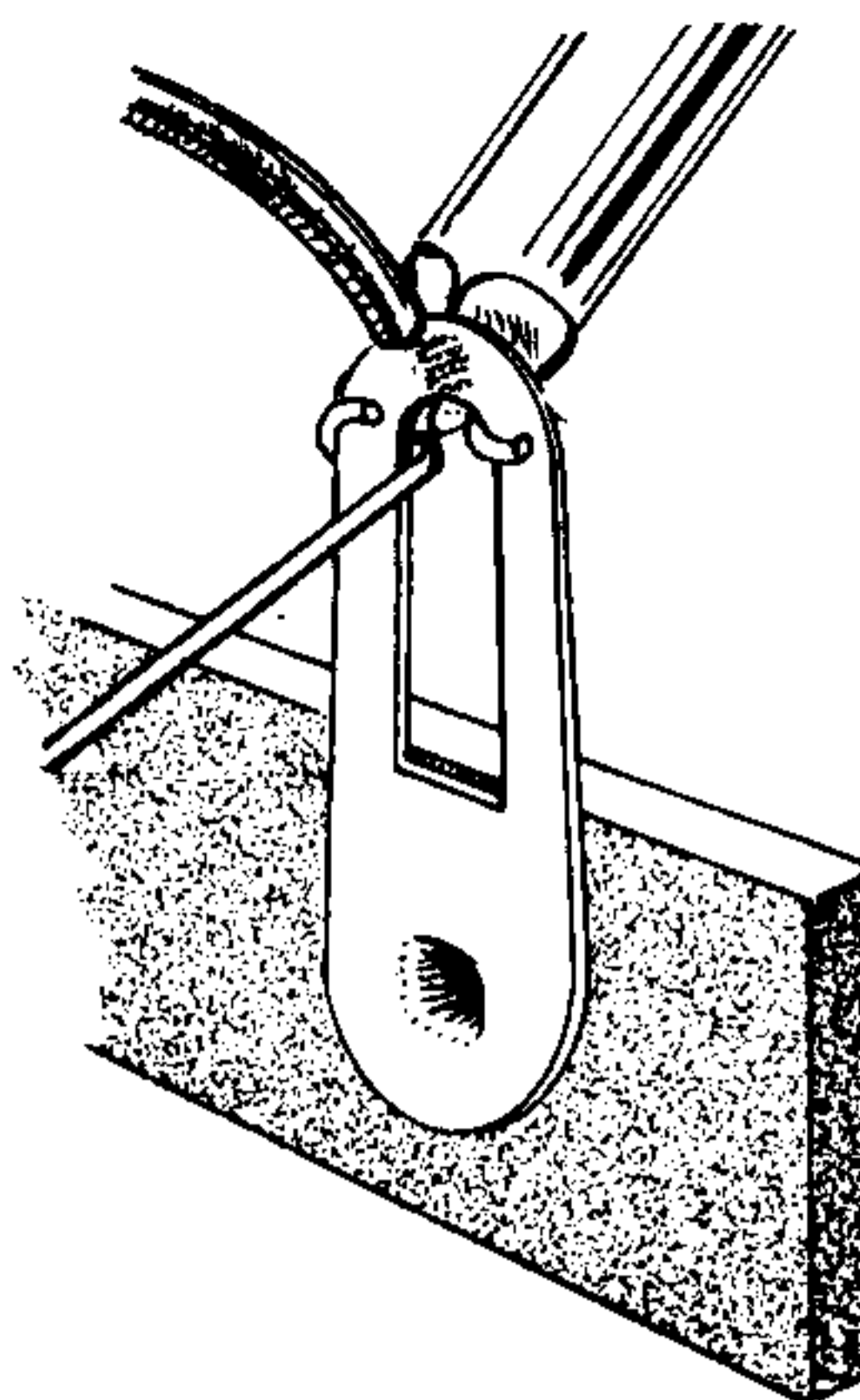

APPLY SOLDER

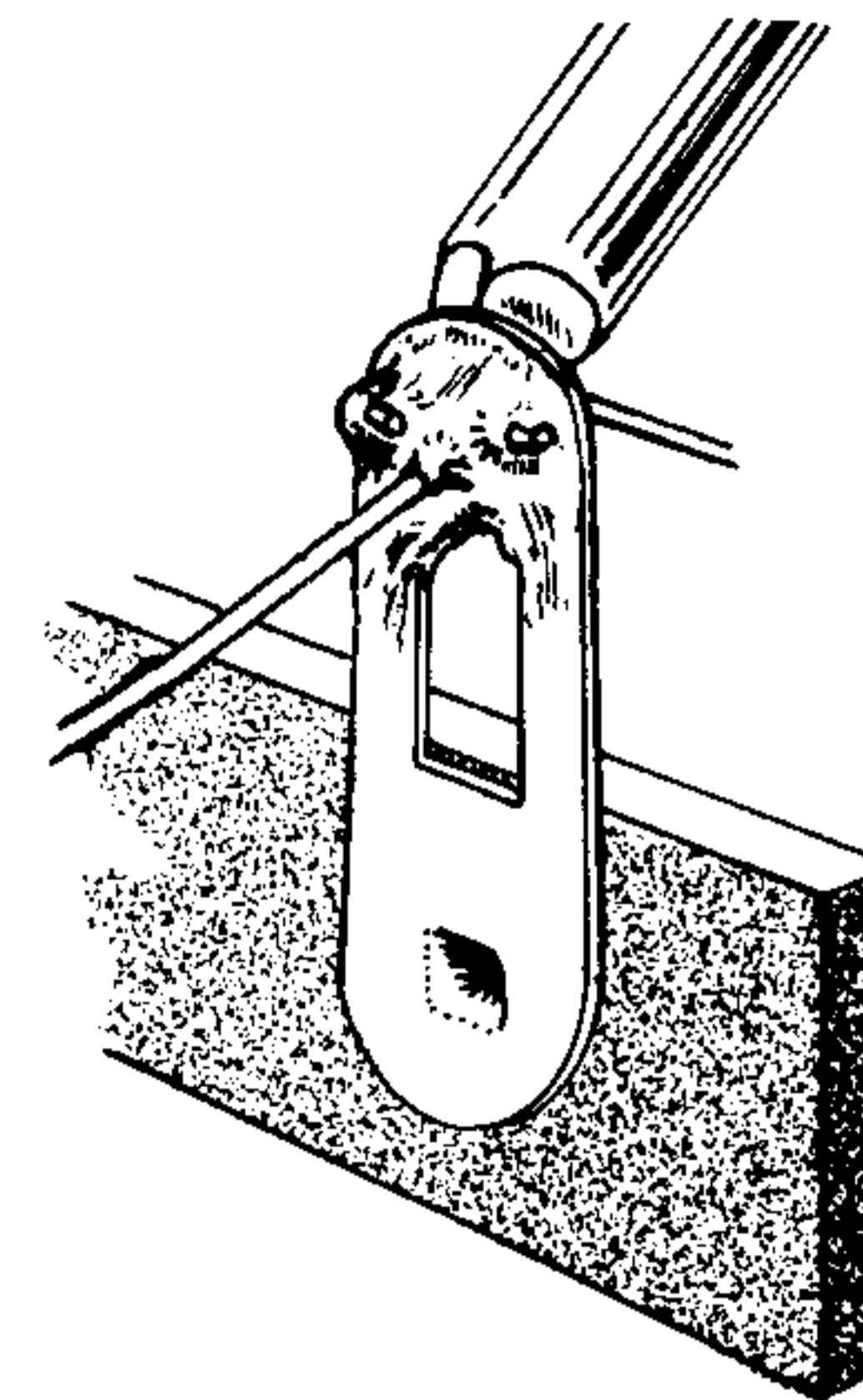

ALLOW SOLDER  
TO FLOW

Take these precautions and use reasonable care during assembly of the kit. This will insure the wonderful satisfaction of having the instrument operate perfectly the first time it is turned on.

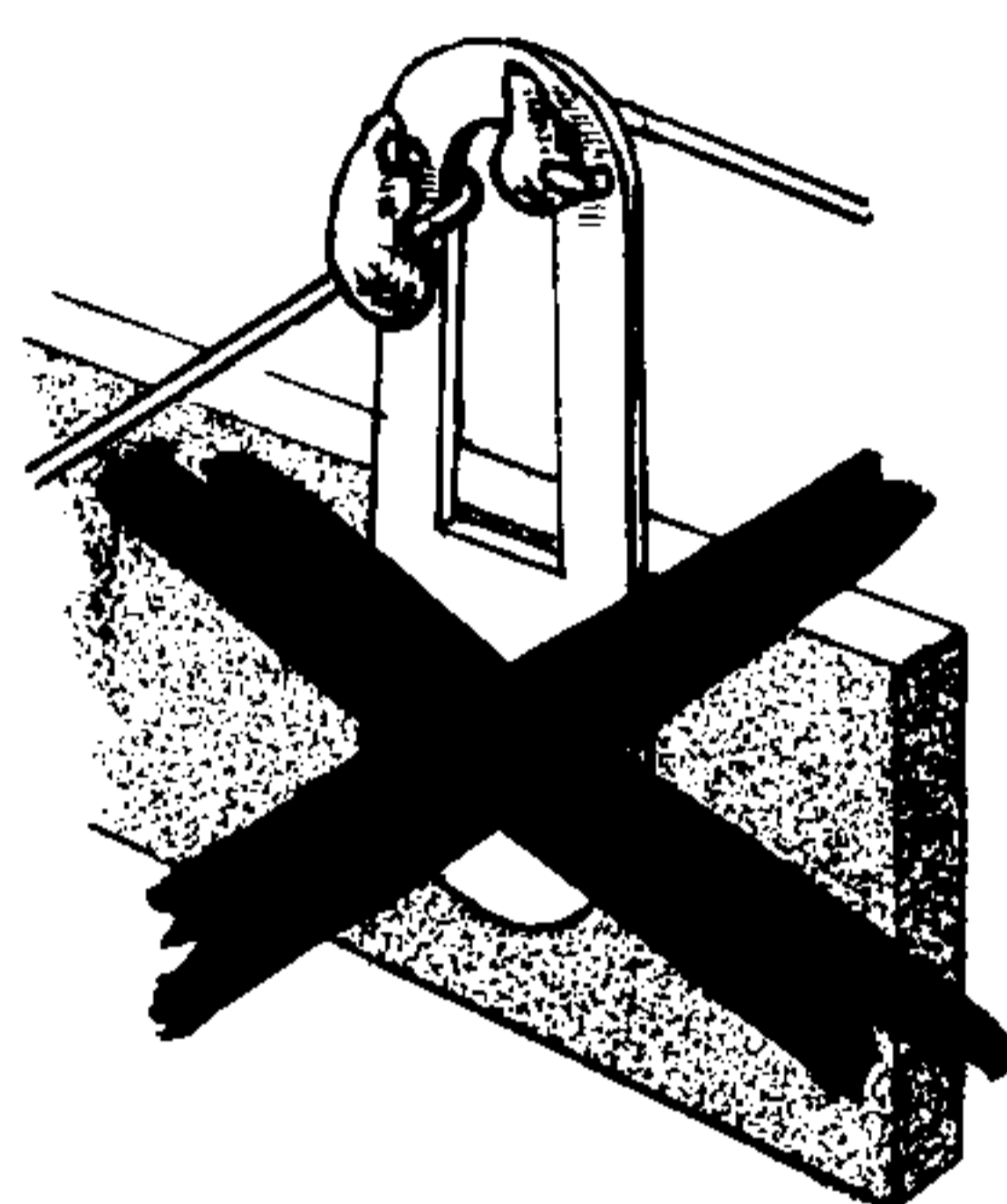

COLD SOLDER JOINT  
CONNECTION INSUFFICIENTLY  
HEATED

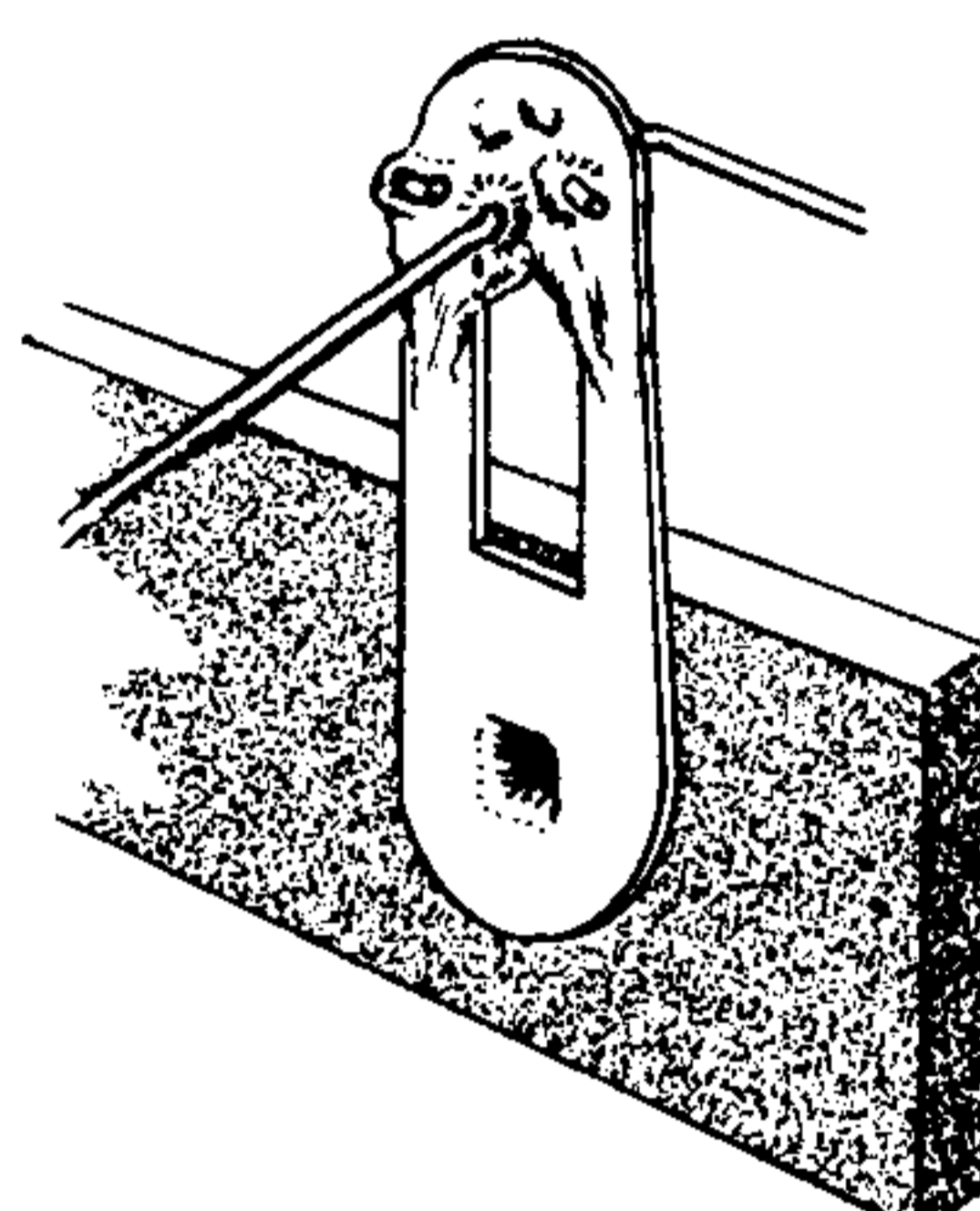

PROPER SOLDER  
CONNECTION

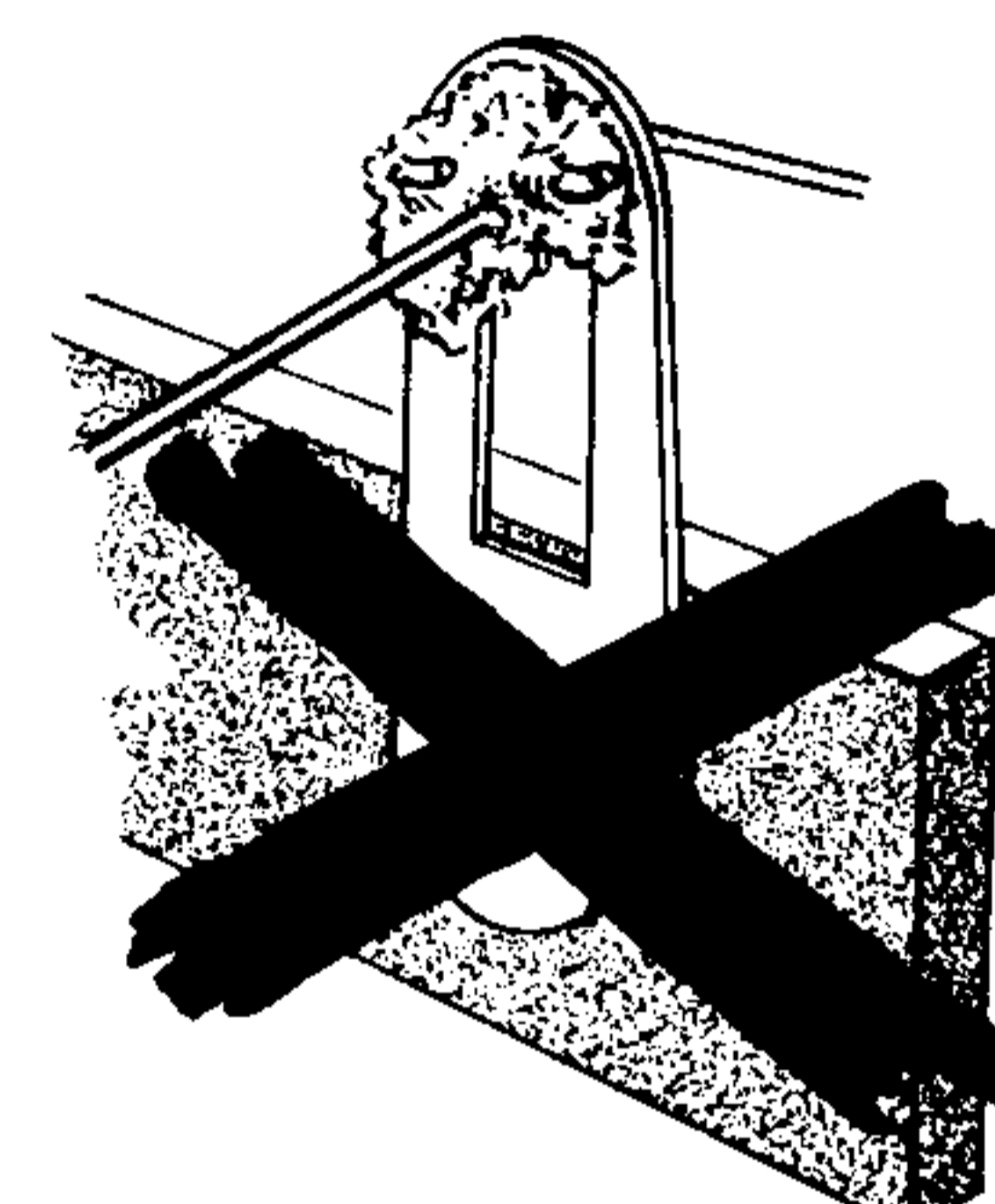

COLD SOLDER JOINT  
CONNECTION MOVED  
WHILE COOLING

### IMPORTANT

In the step-by-step procedure the abbreviation "NS" indicates that the connection should not be soldered as yet, for other wires will be added. When the last wire is installed, the terminal should be soldered and the abbreviation "S" is used to indicate this. Note that a number appears after each solder (S) instruction. This number indicates the number of leads connected to the terminal in question. For example, if the instructions read, "Connect one lead of a 47 K $\Omega$  resistor to lug 1 (S-2)" it will be understood that there will be two leads connected to the terminal at the time it is soldered. This additional check will help avoid errors.

Use lockwashers under all 6-32 and 8-32 nuts. Lockwashers should be placed between controls and the chassis. When solder lugs are mounted under 6-32 nuts, the use of lockwashers is unnecessary.

Don't apply too much solder to the solder joint. Don't apply the solder to the iron only, expecting that it will roll down to the connection. Try to follow the instructions and illustrations as closely as possible.

Don't bend a lead more than once around a connecting point. If it should have to come off due to a mistake or for maintenance it will be much easier to remove.

Keep your soldering iron clean. Wipe it quickly from time to time with steel wool or a rag.

When two or more connections are made to the same solder lug a common mistake is to neglect soldering the connections on the bottom. Make sure all the wires are soldered.

## PANEL ASSEMBLY

- ( ) Locate the short 6/32 screw and set aside to be used later.
- ( ) Mount binding post A using a 6-32 nut. Position solder lug as shown in Pictorial 1.
- ( ) In like manner, mount binding post F, G and H.

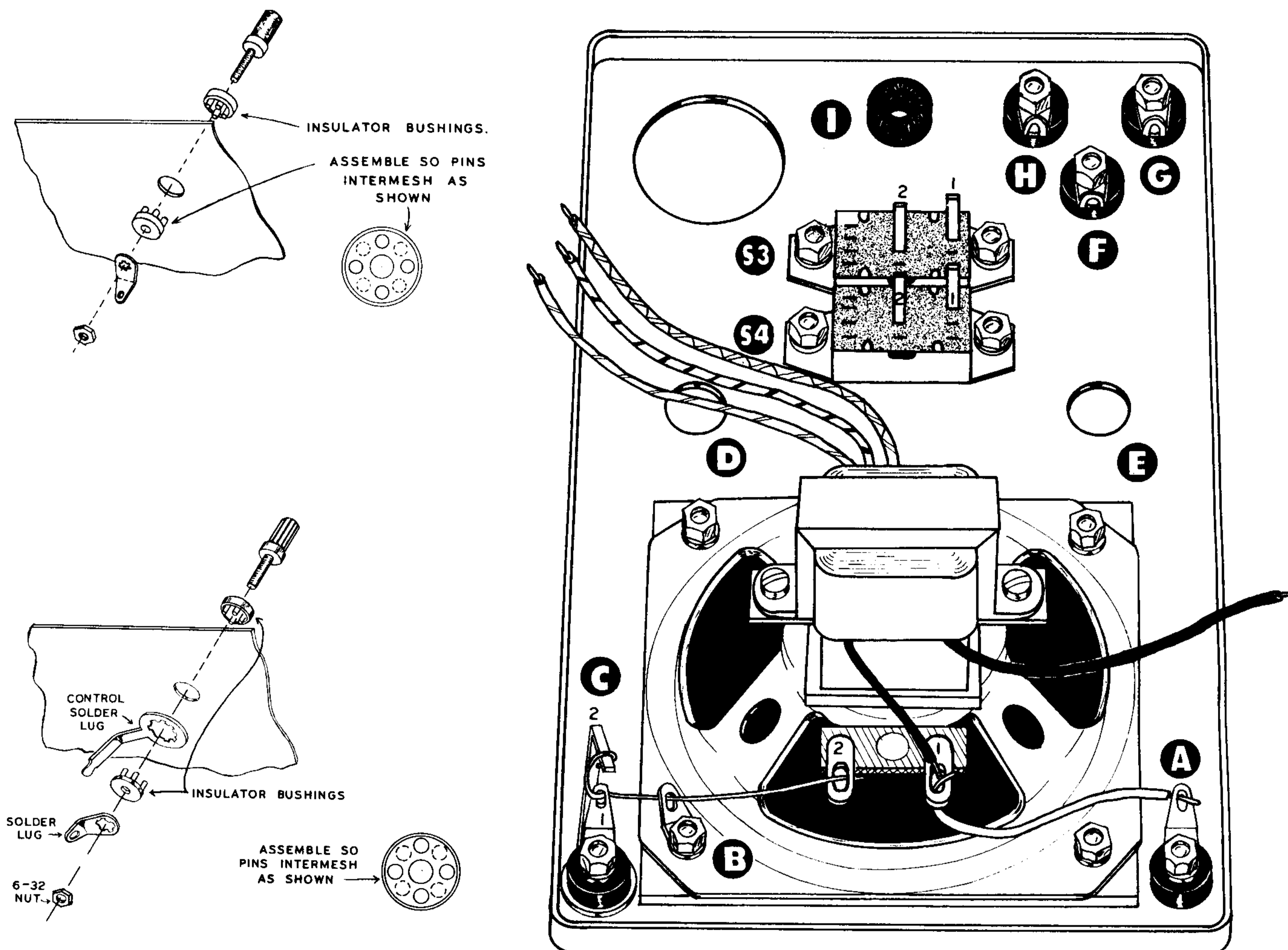

PICTORIAL 1

- ( ) Mount binding post C with a control solder lug under the bushing. See Pictorial 1.
- ( ) Mount the speaker switch S4 as shown in Pictorial 1. Use 6-32 screws, lockwashers and nuts.
- ( ) In like manner, mount the noise switch S3.
- ( ) Insert the 3/8 grommet I.

- ( ) Mount the output transformer on the speaker so the two black wires are next to the voice coil terminals. Use 6-32 hardware.

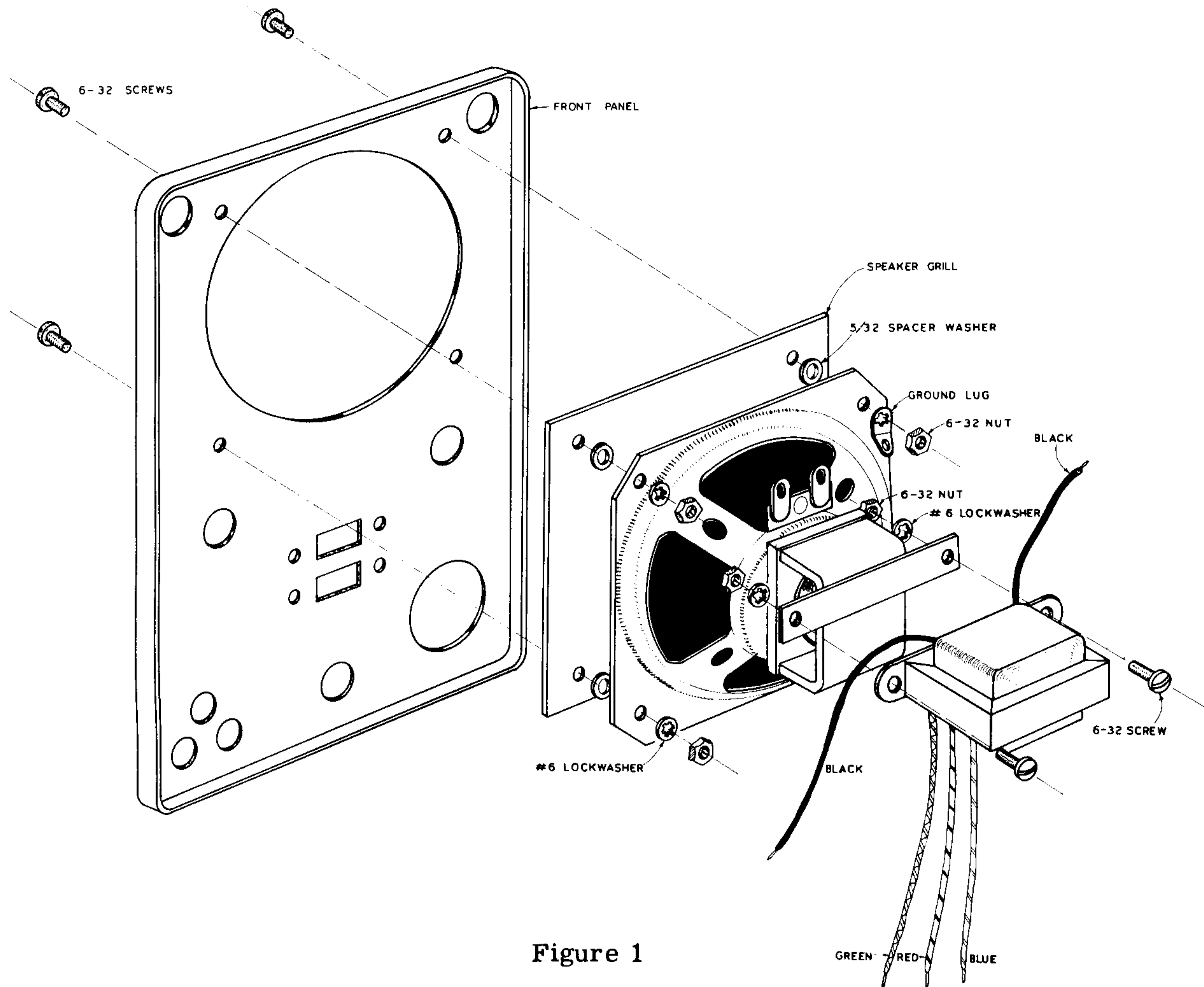
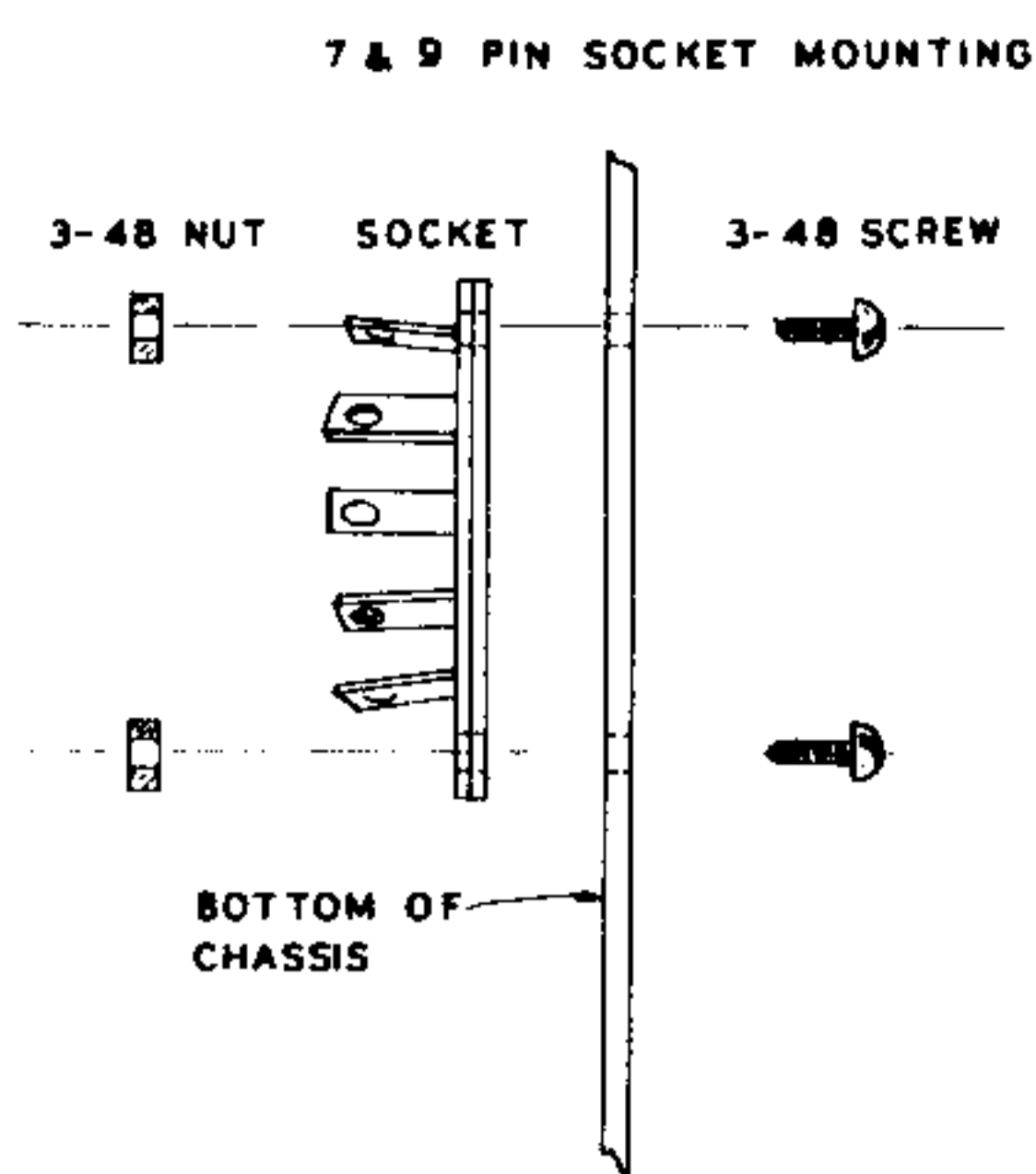

Figure 1

- ( ) Mount the speaker and the speaker grill to the panel. Place a spacer washer between speaker and grill. At the same time mount ground lug B. Use 6-32 hardware.
- ( ) Connect one end of a 2 1/2" length of bare wire to speaker lug 2 (S). Feed the other end thru ground lug B (S), thru terminal lug C1 (S) and wrap around panel ground lug C2 (S).
- ( ) Cut one of the black leads of the output transformer to length, strip the end and connect to speaker lug 1 (NS).
- ( ) Connect one end of a 2" length of hookup wire to terminal lug A (S). Connect the other end to speaker lug 1 (S2).

This completes the panel assembly and wiring. Set aside to be mounted on the chassis later.

## CHASSIS ASSEMBLY



- ( ) Mount the 9 pin wafer tube socket V1 on the underside of the chassis as shown in Pictorial 3. Use 3-48 hardware. (No lockwashers are used with 3-48 hardware.)
- ( ) In like manner mount the 7 pin wafer tube socket V2 as shown in Pictorial 3. Use 3-48 hardware.
- ( ) Mount the C7 condenser mounting wafer on top of the chassis, observing ground lug slot location as shown in Pictorial 3. Use 6-32 screws, lockwashers and nuts.

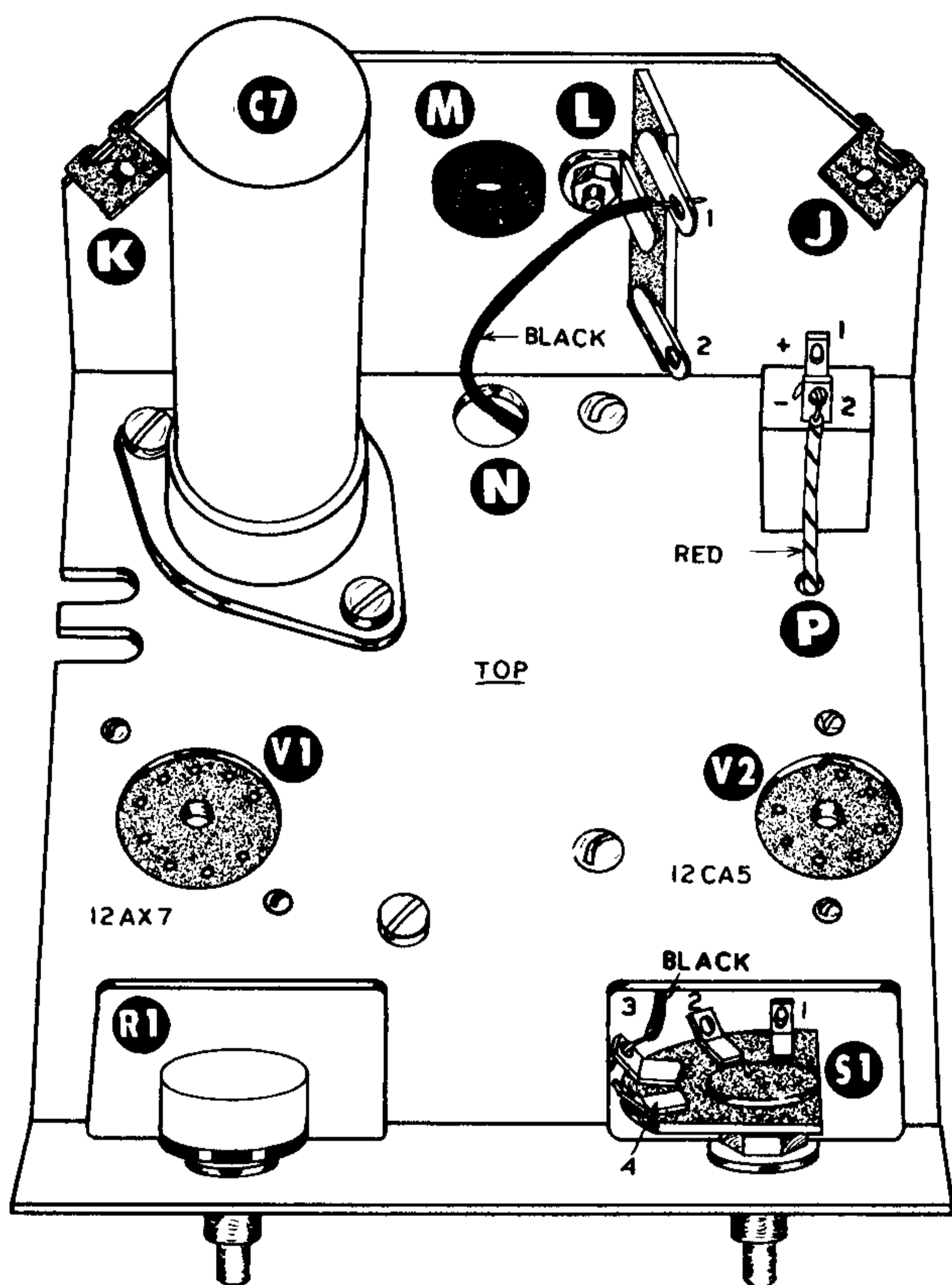
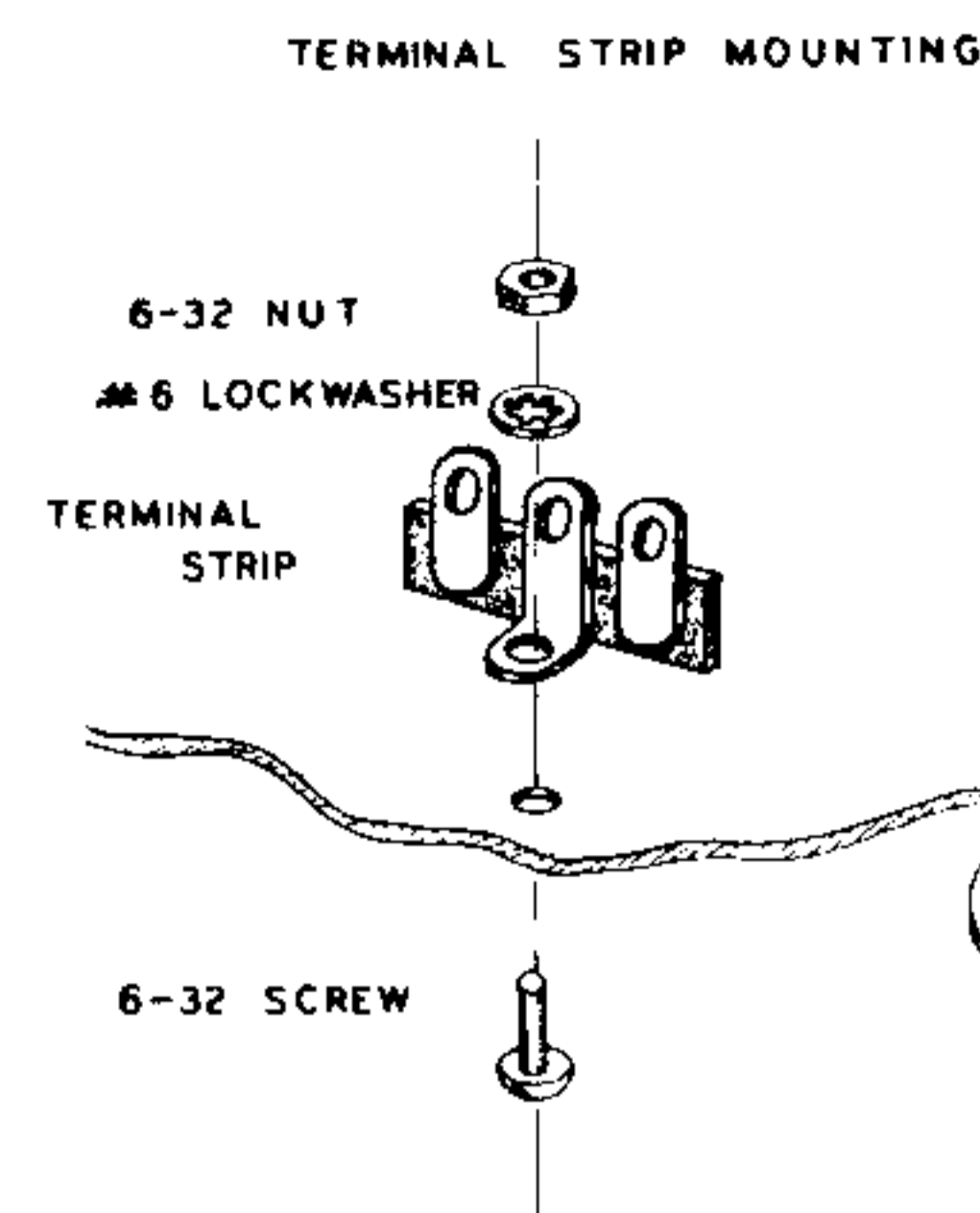

PICTORIAL 2

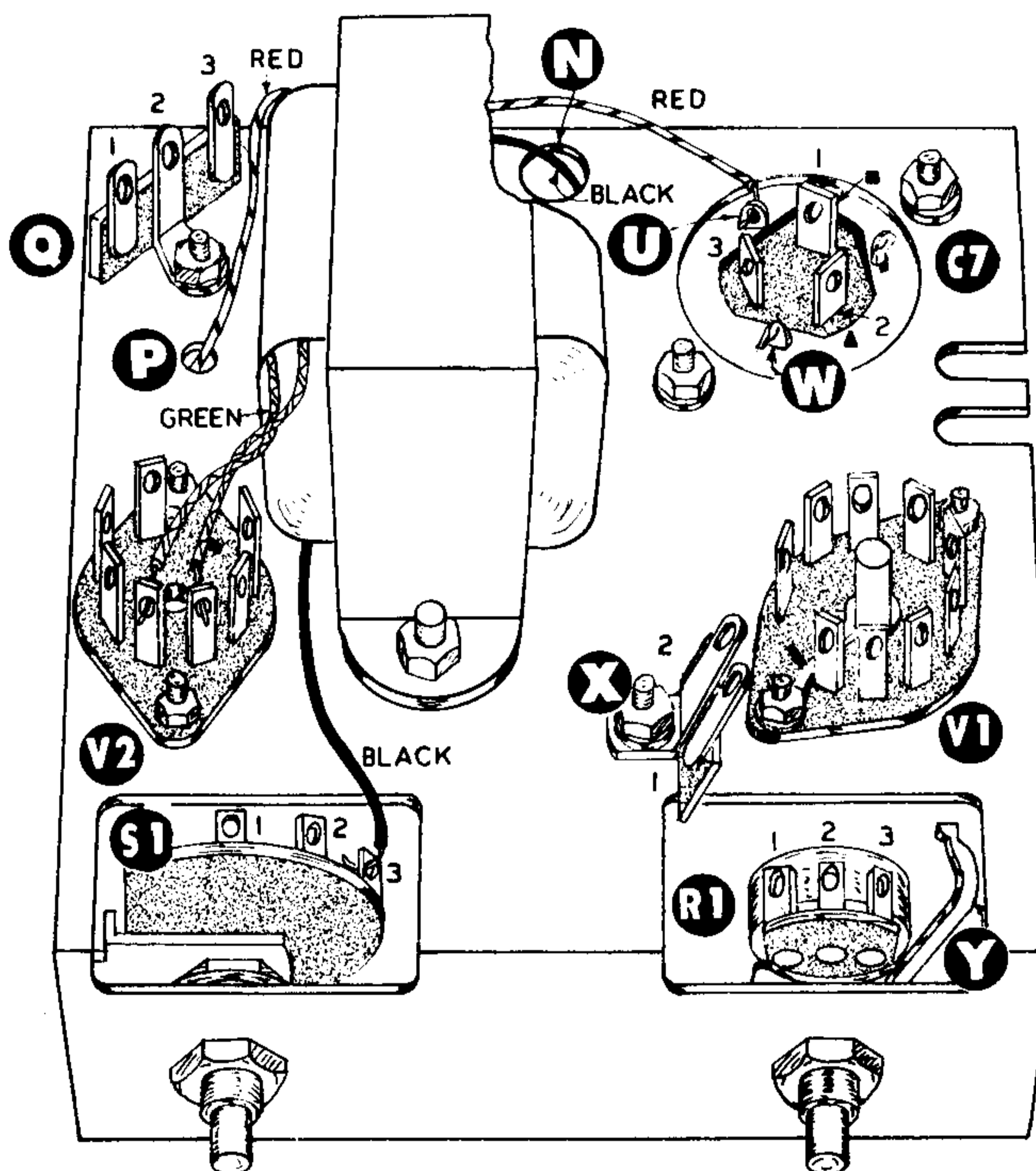

PICTORIAL 3

- ( ) Mount the 2 lug terminal strip X. Use 6-32 hardware.
- ( ) Turn the chassis over and mount the 2 lug terminal strip L.
- ( ) Observing polarity, mount the selenium rectifier and at the same time mount the 3 lug terminal strip Q. Use a 6-32 lockwasher and nut.

- ( ) Slip the two speed nuts J and K over the corners of the rear apron of the chassis. Make sure that the flat side of the clip is towards the back and the holes in the clips are centered over the holes in the chassis.

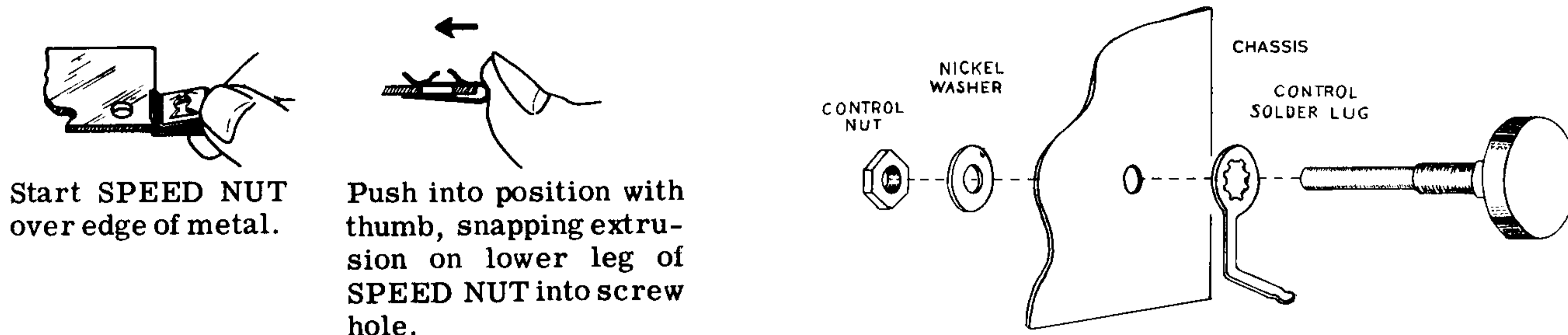

- ( ) Insert the 3/8 grommet M.
- ( ) Temporarily, mount the 1 meg level control R1 using a control solder lug. Position as shown in Pictorials 2 and 3.
- ( ) In like manner mount the off-on switch S-1 using a control lockwasher between chassis and switch.
- ( ) Mount the filter condenser C7 so the lug marked with a square is towards the rear of the chassis. Twist the mounting lugs 1/8 turn only.
- ( ) Mount the power transformer on the bottom side of the chassis with the wires towards the V2 tube socket. Use 8-32 hardware.

This completes the parts mounting, check all parts for correct position and make sure all screws and nuts are tightened securely.

#### CHASSIS WIRING

- ( ) Connect the short black wire of the power transformer to lug 3 (S) of the off-on switch S1.

- ( ) Twist the two green filament wires of the transformer together, and connect one wire to pin 3 (NS) and the other wire to pin 4 (NS) of tube socket V2.
- ( ) Connect one red transformer wire to ground lug U (NS) of condenser C7.

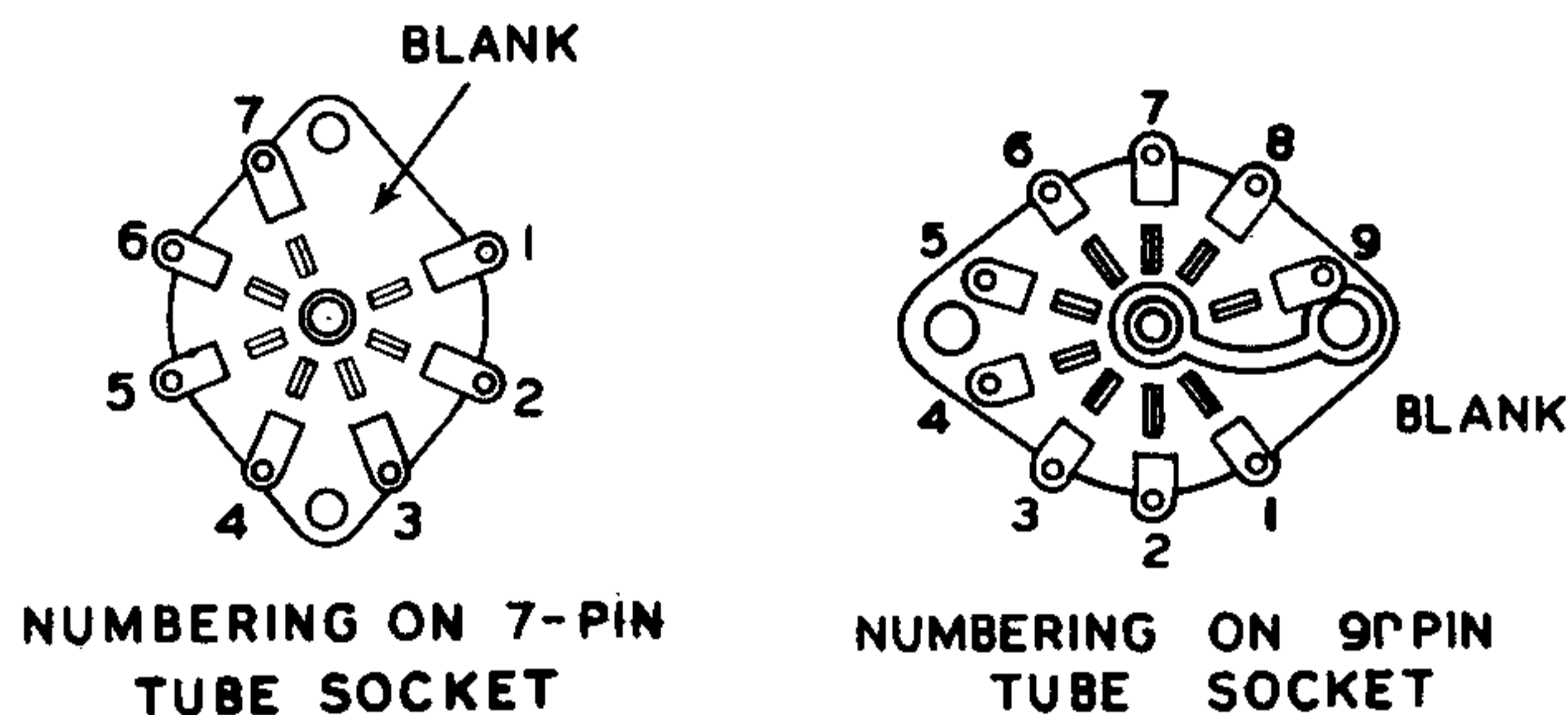

- ( ) Feed the other red wire from the power transformer through hole P and connect to lug 2 (S) or negative side of selenium rectifier.
- ( ) Feed the remaining black wire through hole N and connect to lug 1 (NS) of terminal strip L.

- ( ) Connect one end of a 2" length of bare wire to pin 3 (S) of V1 tube socket. Feed the other end through the center ground lug (S), through pin 9 (S) and connect to lug 2 (NS) of terminal strip X.
- ( ) Cut two 5" lengths of hookup wire and strip both ends. Twist the wires together and connect one wire to pin 3 (S2) of tube socket V2. Connect the other wire to pin 4 (S2). Connect the other ends to pin 4 (NS) and 5 (NS) of socket V1.

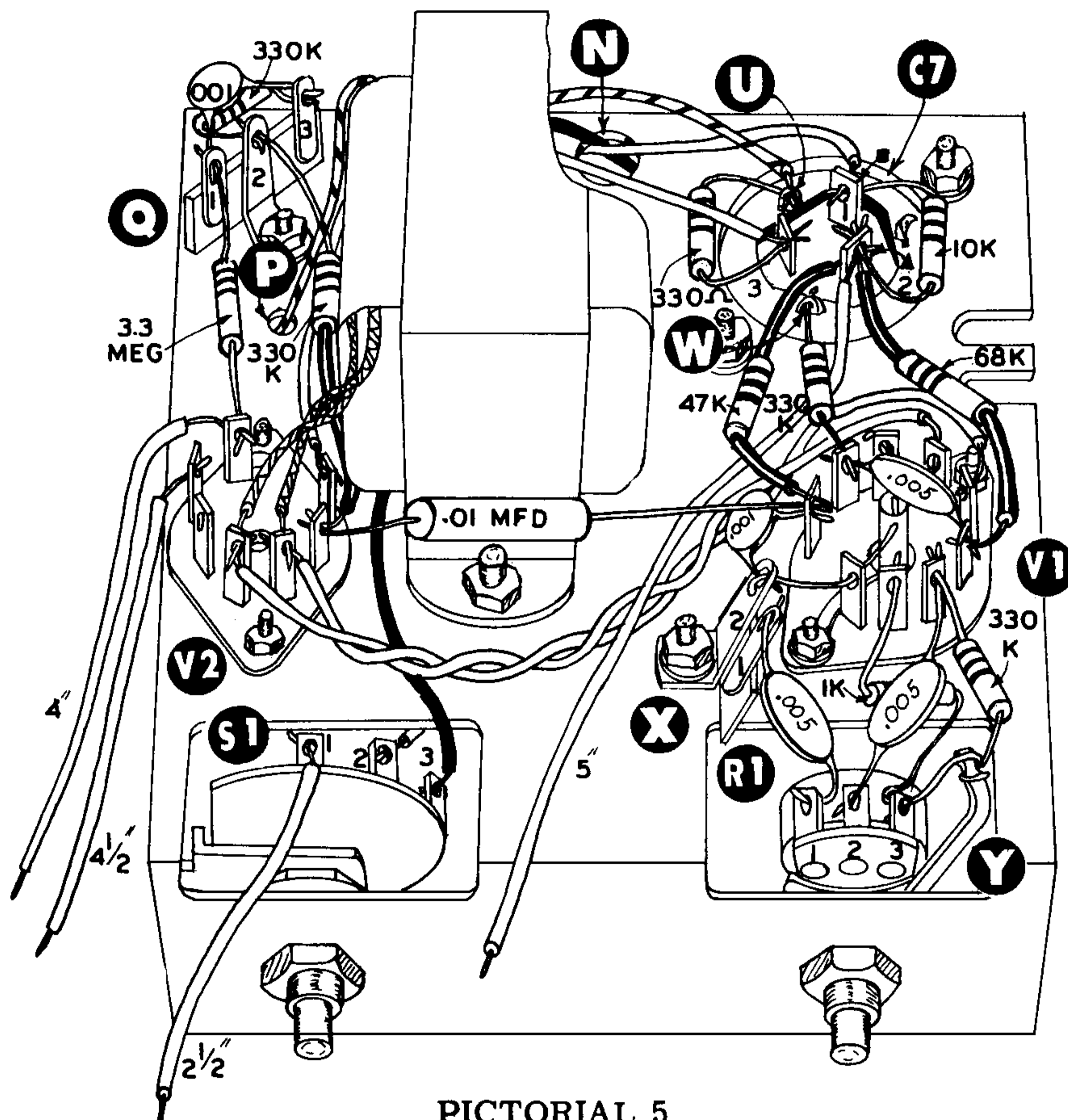

PICTORIAL 5

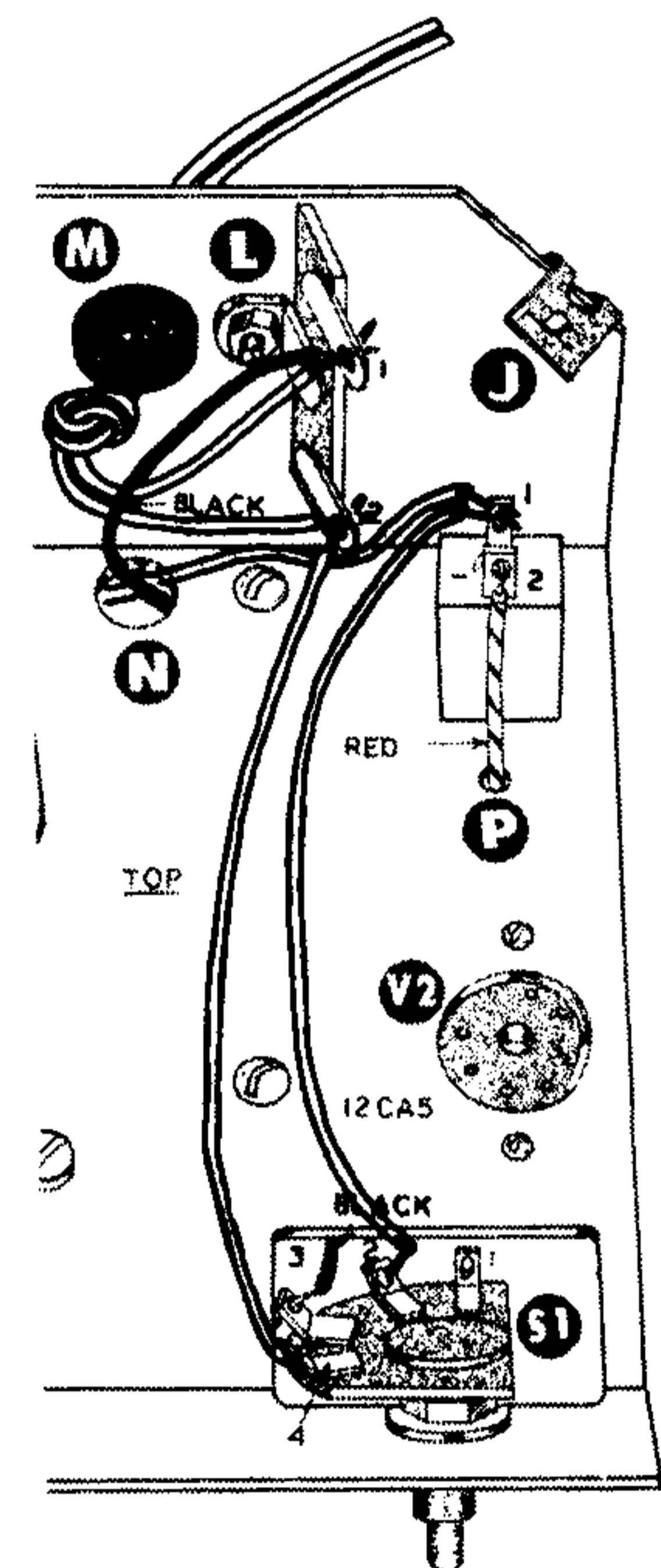

- ( ) Connect one end of 4 1/2" length of hookup wire to pin 1 (S) of V2. Connect the other end to lug 3 (NS) of filter condenser C7.
- ( ) Connect one lead of a 330 ohm resistor (orange-orange-brown) to lug 3 (S2) of C7. Connect the other lead to ground lug U (S2).
- ( ) Connect one lead of a 10 K ohm resistor (brown-black-orange) to lug 1 (NS) of C7. Connect the other lead to lug 2 (NS).
- ( ) Strip both ends of a 5" length of hookup wire, and connect one end to lug 2 (NS) of C7. Dress the wire towards the front of the chassis.
- ( ) Connect one lead of a 330 K ohm resistor (orange-orange-yellow) to pin 2 (NS) of socket V1. Connect the other lead to ground lug W (S).
- ( ) Connect one lead of a 47 K ohm resistor (yellow-violet-orange) to pin 1 (NS) of socket V1. Connect the other lead to lug 2 (NS) of C7. Use sleeving on both leads.

- ( ) Connect one lead of a 68 K ohm resistor (blue-grey-orange) to pin 6 (NS) of V1. Connect the other lead to lug 2 of C7 (S4). Use sleeving on both leads.
- ( ) Connect one lead of a .005 mfd ceramic disc condenser to pin 2 (S2) of V1. Connect the other lead to pin 6 (S2).
- ( ) Feed one lead of a 1 K ohm resistor (brown-black-red) through lug 3 (S) of the level control R1 and wrap around the control solder lug Y (NS). Connect the other lead to pin 8 (S) of V1.
- ( ) Connect one lead of a 330 K ohm resistor (orange-orange-yellow) to pin 7 (NS) of V1. Wrap the other lead around solder lug Y (S2).
- ( ) Connect one lead of a .005 mfd ceramic condenser to pin 7 (S2) of V1. Connect the other lead to lug 2 (S) of control R1.
- ( ) Connect one lead of a .005 mfd ceramic condenser to lug 1 (S) of control R1. Connect the other lead to lug 1 (NS) of terminal strip X.
- ( ) Connect one lead of a .001 mfd ceramic disc condenser to pin 1 (NS) of socket V1. Connect the other lead to lug 2 (NS) of terminal strip X.
- ( ) Connect one lead of a .01 mfd tubular condenser to pin 1 (S3) of tube socket V1. Connect the other lead to pin 2 (NS) of tube socket V2.
- ( ) Connect one lead of a 330 K ohm resistor (orange-orange-yellow) to pin 2 (S2) of socket V2. Use sleeving. Connect the other lead to lug 2 (NS) of terminal strip Q.
- ( ) Connect one lead of a 330 K ohm resistor (orange-orange-yellow) to lug 3 (NS) of terminal strip Q. Connect the other lead to lug 2 (NS).
- ( ) Connect one lead of a .001 mfd ceramic condenser to lug 1 (NS) of terminal strip Q. Connect the other lead to lug 3 (NS).
- ( ) Connect one lead of a 3.3 megohm resistor (orange-orange-green) to lug 1 (S2) of terminal strip Q. Connect the other lead to pin 7 (NS) of tube socket V2.
- ( ) Strip both ends of a 4" length of wire and connect one end to pin 7 of V2 (S2). Dress the wire towards front of chassis.
- ( ) Strip both ends of a 4 1/2" length of wire and connect one end to pin 6 (S) of V2. Dress towards the front center of chassis.
- ( ) Strip both ends of a 2 1/2" length of wire and connect one end to lug 1 (S) of switch S1.
- ( ) Connect one end of a 4 1/2" length of wire to lug 1 (NS) of condenser C7. Feed the other end through hole N and connect to lug 1 (NS) or the positive side of the selenium rectifier on the top side of the chassis.
- ( ) Connect one end of a 5 1/2" length of wire to lug 1 (S2) of selenium rectifier. Connect the other end to lug 2 (S) of switch S1.
- ( ) Connect one end of a 5" length of wire to lug 2 (NS) of terminal strip L. Connect the other end to lug 4 (S) of switch S1.
- ( ) Feed the line cord through grommet M and tie a knot in the cord approximately 1 1/2" from the end. Connect one wire to lug 1 (S2) and the other wire to lug 2 (S2) of terminal strip L.

## PREPARING THE EYE TUBE ASSEMBLY

- ( ) Start the two #6 sheet metal screws in the eye tube mounting bracket.
- ( ) Mount the spring tube holder on the bracket using the short 6-32 screw and a lockwasher and nut.
- ( ) Prepare the 8 pin wafer tube socket by bending the lugs as shown with a pair of long nose pliers.
- ( ) Connect one end of a 1 meg resistor (brown-black-green) to pin 3 (S). Connect the other end to pin 4 (NS).
- ( ) Prepare the 6" length of 8-wire cable by cutting 3" of the plastic cover off one end and 2" off the other end.
- ( ) Pull the black, white and yellow wires out of the cable.

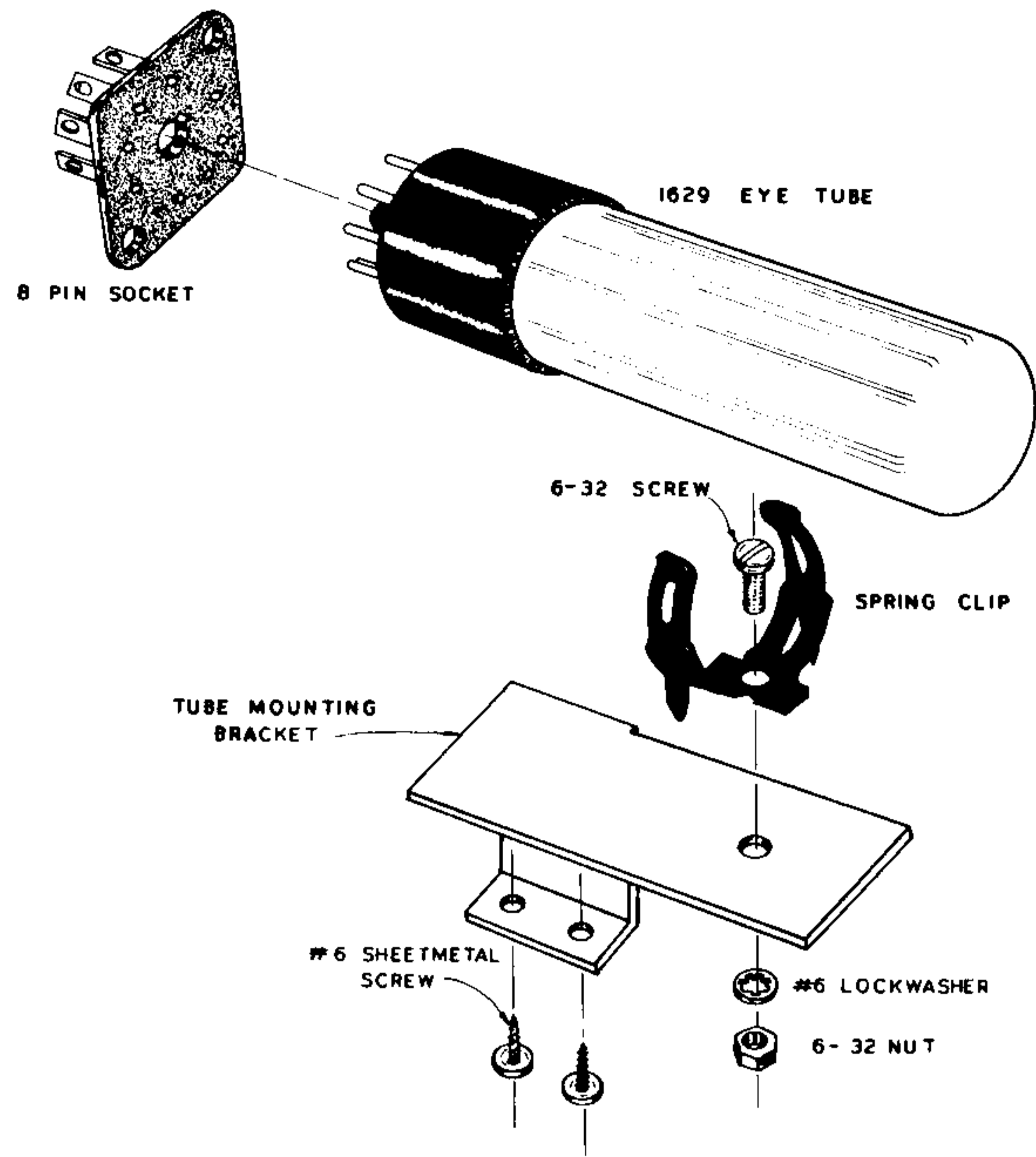
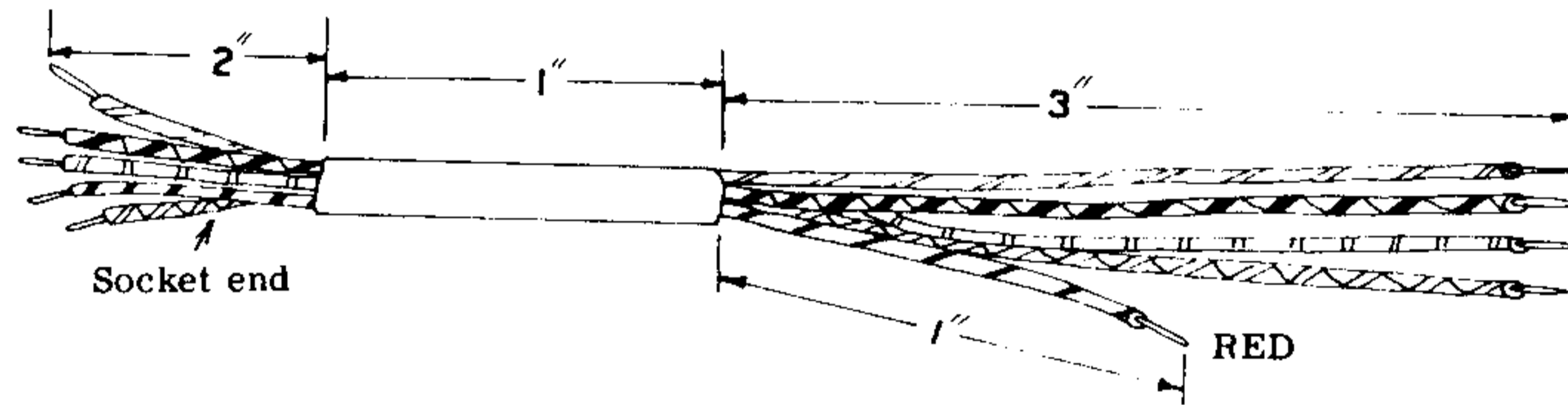
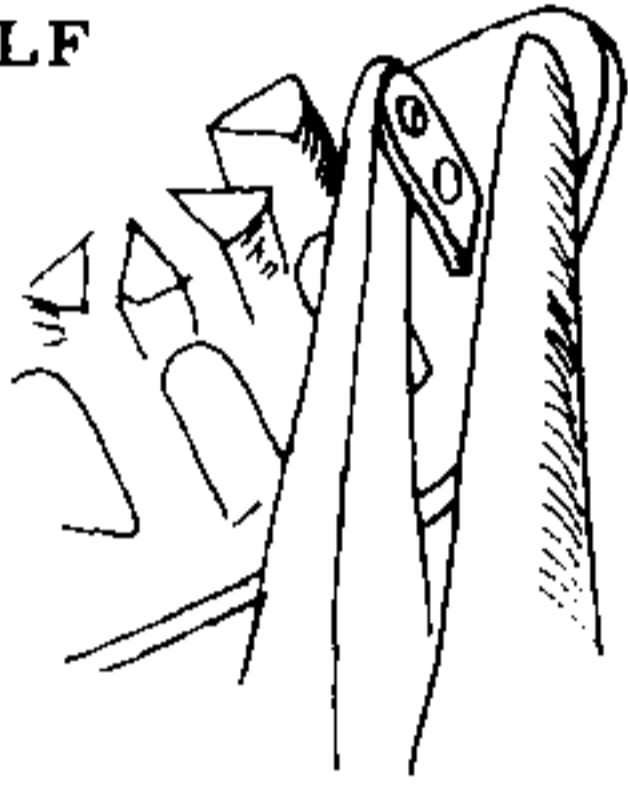

Figure 2



1- GRASP UPPER HALF OF LUG



2- BEND LUG SLIGHTLY AS SHOWN TO CLEAR PIN SLEEVE IN FRONT

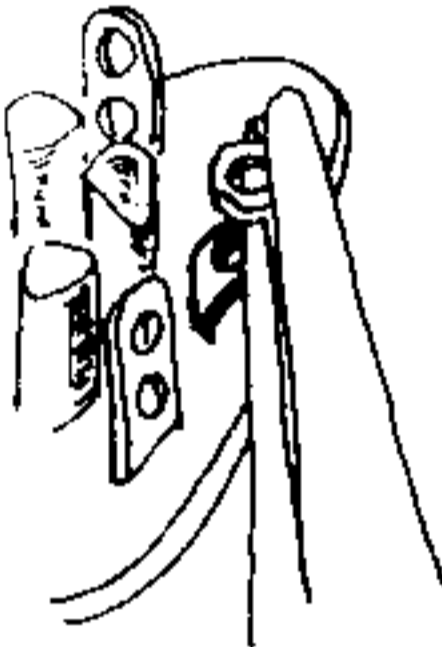

3- NOW BEND LUG UNTIL IT POINTS DOWN AS SHOWN

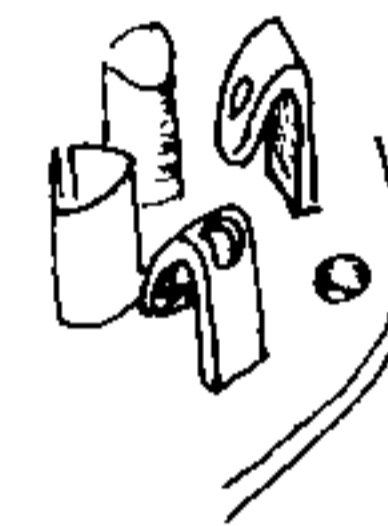
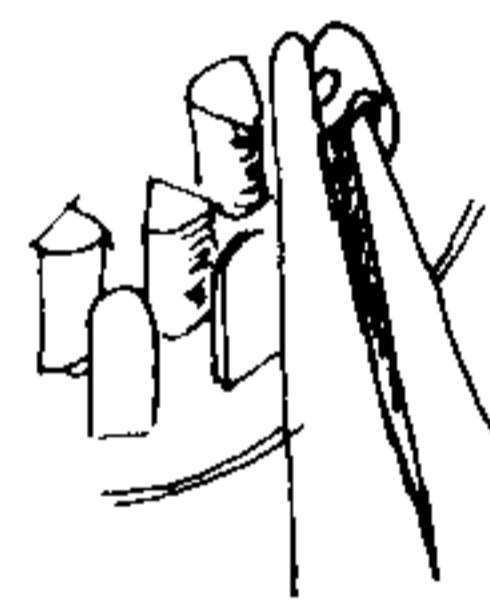

- ( ) Cut 2" off the red wire and strip both ends of all the wires.
- ( ) Connect the blue wire to pin 2 (S) of the eye tube.
- ( ) Connect the red wire to pin 4 (S2).
- ( ) Connect the green wire to pin 5 (S).
- ( ) Connect the orange wire to pin 7 (S).
- ( ) Connect the brown wire to pin 8 (S).
- ( ) Plug the socket on the 1629 eye tube and push the tube into the spring clip holder.

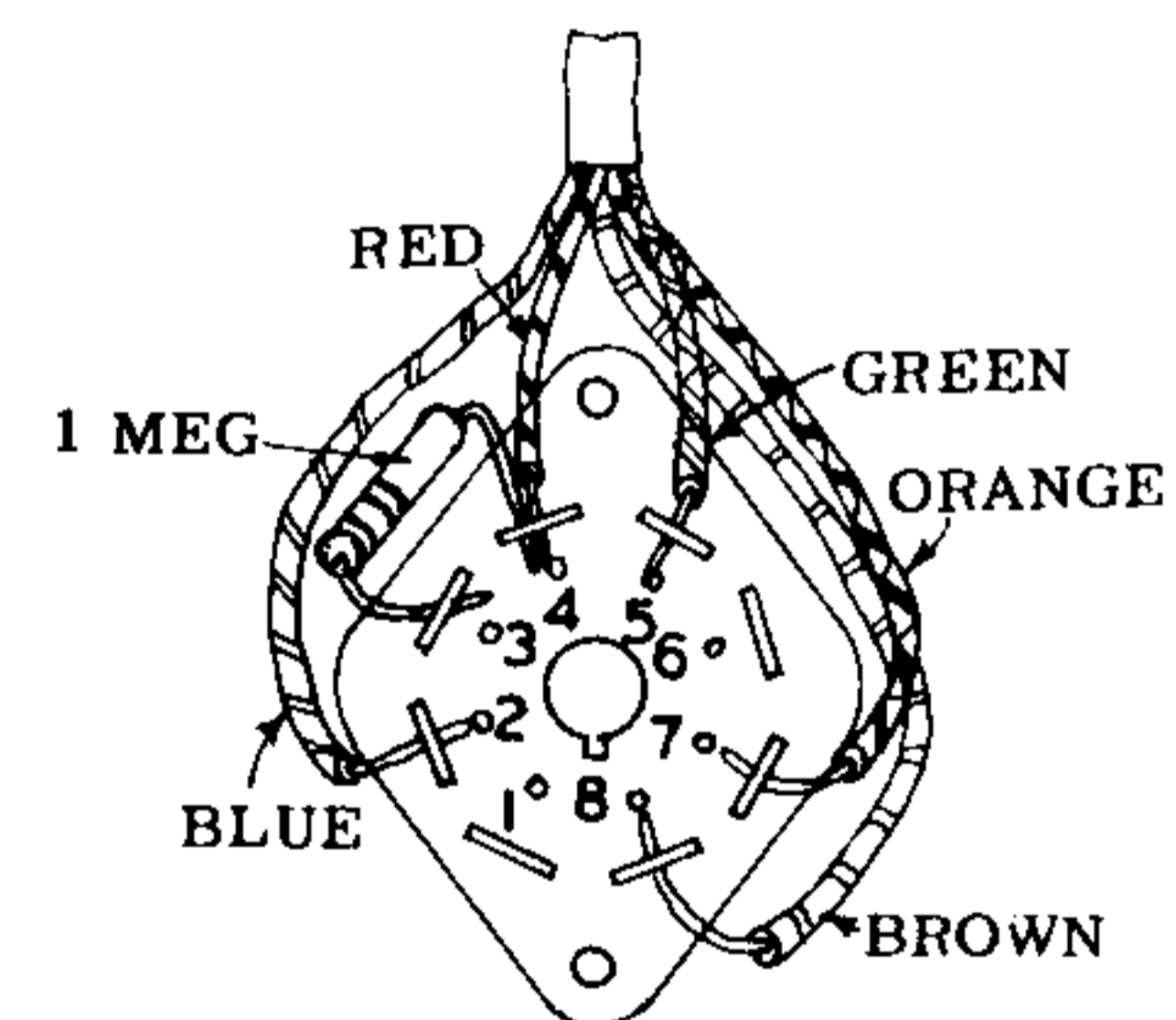

## PREPARING THE PROBE AND TEST LEADS

- ( ) Mount the RF-Audio switch S2 on the terminal board by bending the lugs on the switch as shown.

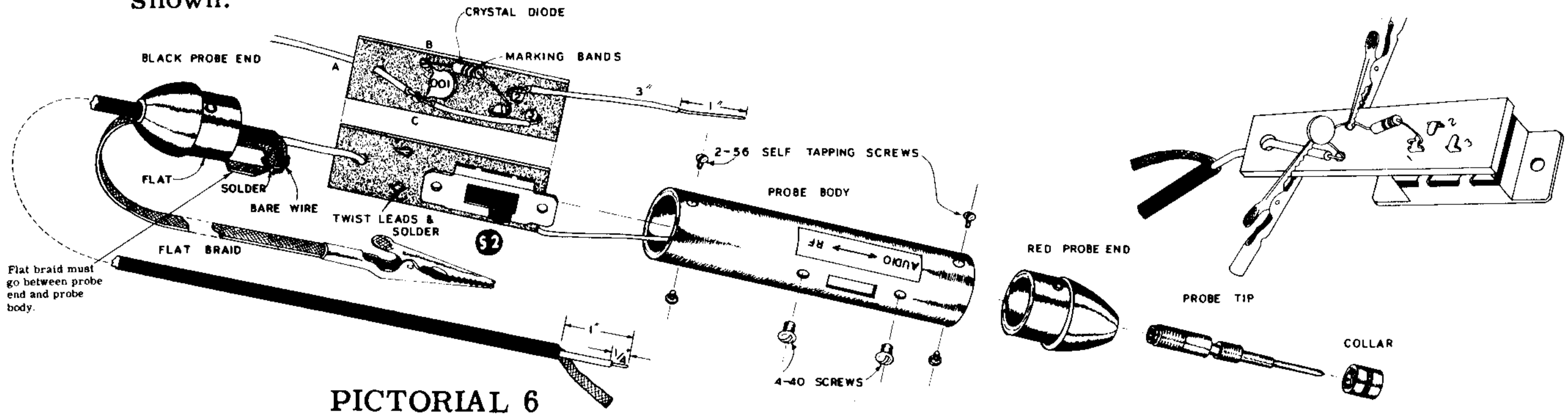

PICTORIAL 6

- ( ) Push one end of a 1 3/4" length of wire through hole C of the terminal board. Connect the other end to lug 3 (S) of switch S2.
- ( ) Connect one end of a 3" length of wire to lug 2 (S) of switch S2. Strip the other end approximately 1".
- ( ) Push one lead of a .001 ceramic disc condenser through hole C of the terminal board, and the other lead through hole B.
- ( ) Connect the lead closest to the marking bands of the crystal diode to lug 1 of switch S2 (S). **Caution:** Crystal diodes can be damaged by excessive heat. Use as little heat as possible when soldering. Push the other lead of the diode through hole B and twist together with the condenser lead. Solder the two leads on the switch side of the board and trim off any excess lead. (Use an alligator clip to hold wires in board).

- ( ) Cut away one inch of the outer insulation of the coaxial cable. Double the lead over and pull the center conductor through the side of the braid as shown. Strip off 1/4" of the insulation from the center conductor.

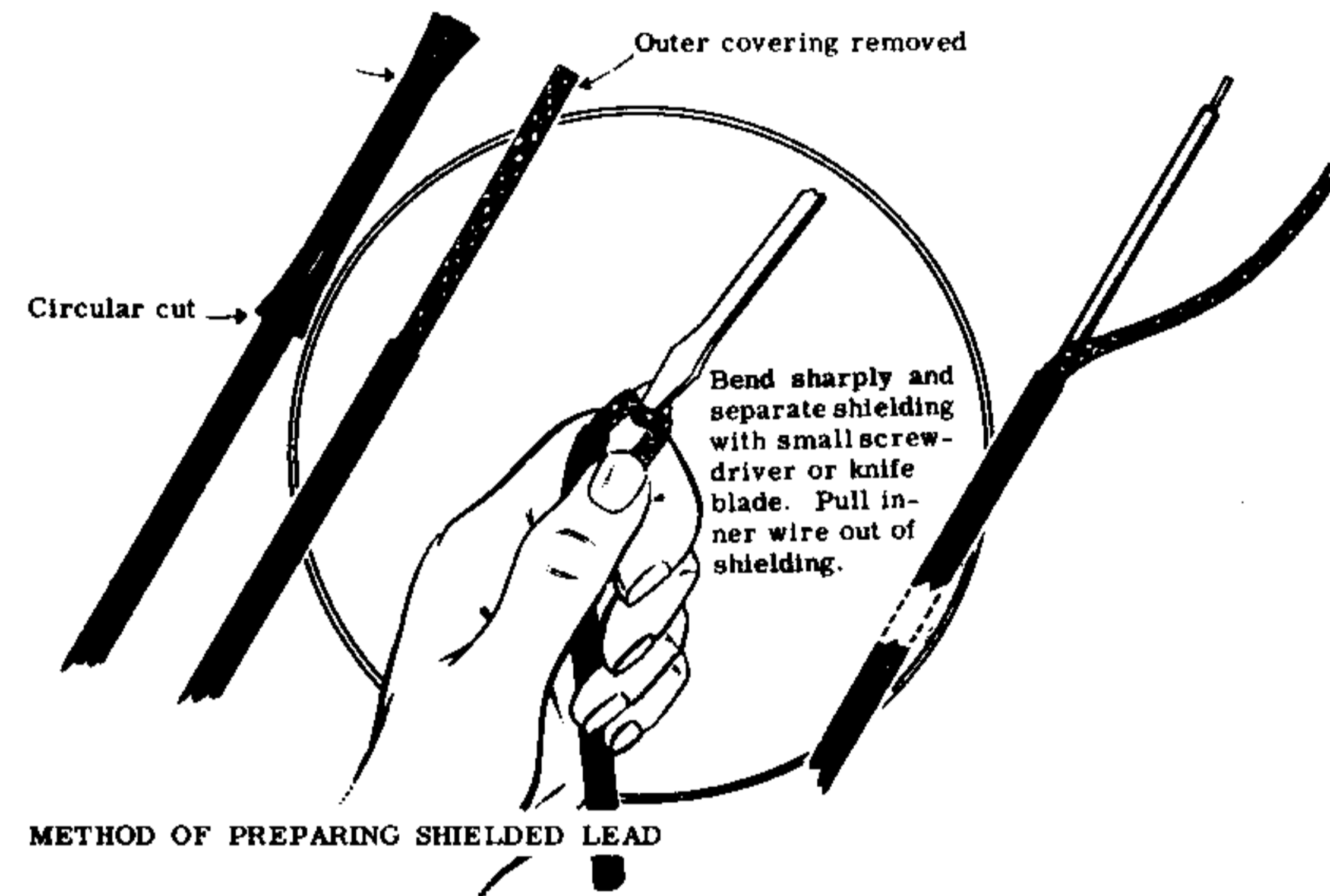

- ( ) Slip the black probe end over the opposite end of the cable and cut off 2" of the outer insulation. Pull the center conductor through the braid, strip off 1/4" of the center conductor insulation and feed the wire through hole A in terminal board, from the switch side. Push the end of the wire through hole C. Twist the three wires together and solder on the switch side of the board, trim off excess lead.

- ( ) Slip the length of flat braid through the probe end and bend over as shown. Wrap a short length of bare wire around the flat braid and the cable shield and solder. Cut off excess cable shield. Do not cut off braid.

- ( ) Solder an alligator clip to the other end of the braid.

- ( ) Slip the terminal board and switch into the probe body and mount the switch with the two small 4-40 screws.

- ( ) Push the black probe end into the end of the probe body, making sure that the flat braid is between the probe body and the flat side of the probe end. Fasten the end with two small self tapping screws.
- ( ) Screw the probe tip into the red probe end, and remove the collar from the tip. Slip the red end into the probe body, making sure the wire comes through the hole in the tip. Secure the end in the probe body with the two self tapping screws. Wrap the wire around the probe tip and replace the collar.
- ( ) Remove the paper backing from the RF audio decal, and place it on the probe body with the audio end towards the tip.
- ( ) Assemble the red and black test leads as shown.

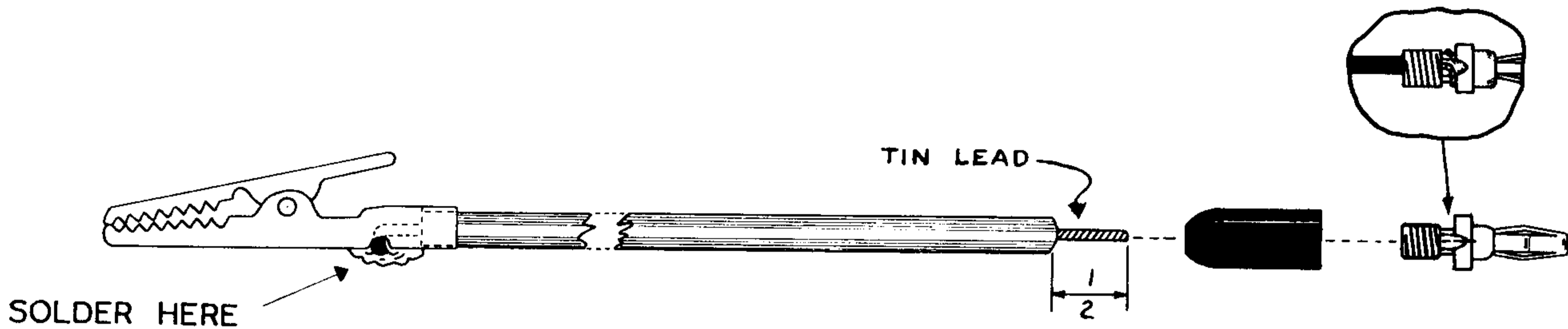

### FINAL ASSEMBLY AND WIRING

- ( ) Remove the 3/8 nuts from control R1 and switch S1. Mount the chassis to the panel using a nickel control washer between the panel and the 3/8 control nuts.
- ( ) Feed the four remaining wires from the output transformer through the chassis slot behind switch S1. Connect the black wire to lug 1 (S) of speaker switch S4.
- ( ) Connect a short length of bare wire between lug 2 (S) of switch S4 and lug 2 (NS) of terminal strip X.
- ( ) Connect one lead of a 68 K ohm resistor (blue-grey-orange) to lug 2 (S) of noise switch S3. Connect the other lead to lug 1 (NS) of terminal strip X.
- ( ) Connect the wire from lug 2 of condenser C7 to lug 1 (NS) of switch S3.
- ( ) Connect the wire from pin 6 of V2 to lug 1 (S2) of switch S3.
- ( ) Connect the lead from lug 1 of the off-on switch to panel terminal H (NS).
- ( ) Connect the green wire from the output transformer to terminal H (S2).
- ( ) Connect the red transformer lead to terminal F (S).
- ( ) Connect the wire from pin 7 of socket V2 to terminal G (NS).

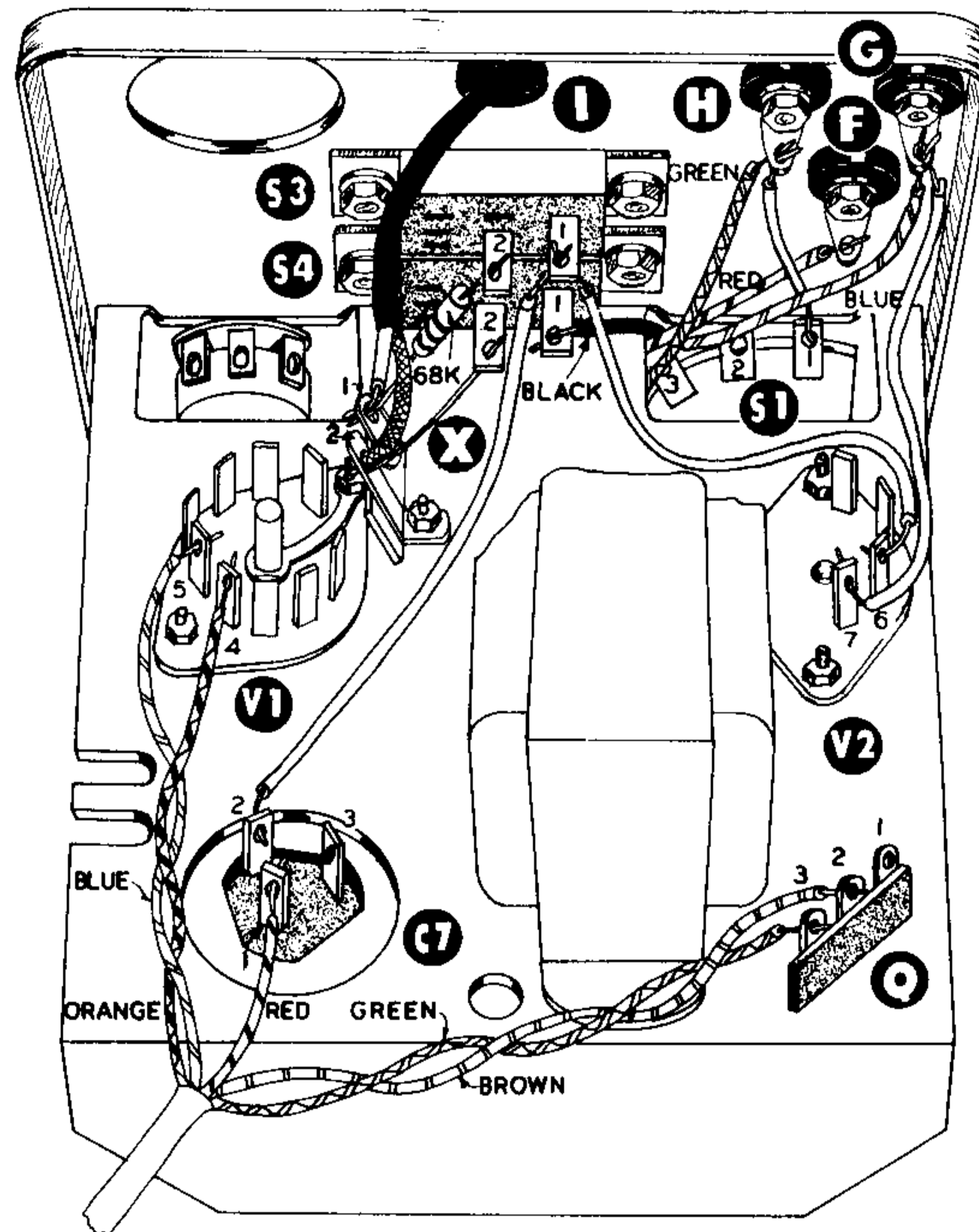

- ( ) Connect the blue transformer wire to terminal G (S2).
- ( ) Feed the probe cable through grommet I and connect the inner conductor to lug 1 (S3) of terminal strip X. Connect the cable shield to lug 2 (S4).
- ( ) Twist the green and brown leads from the eye tube socket and connect the green lead to lug 3 (S3) of terminal strip Q. Connect the brown lead to lug 2 (S3).
- ( ) Connect the red lead to lug 1 (S3) of condenser C7.
- ( ) Twist the orange and blue leads together and connect the orange lead to pin 4 (S2) of socket V1. Connect the blue lead to pin 5 (S2). This completes the T-4 wiring. Check over connections and make sure that all have been soldered.
- ( ) Install the 12AX7, V1 and the 12CA5, V2 tubes.
- ( ) Mount the eye tube by sliding the two sheet metal screws into the slots in the chassis and tightening down, and then push the tube forward against the panel.
- ( ) Install the level control and off-on switch knobs. Position so they line up with panel markings.
- ( ) Install red binding post caps on the speaker and the C. T. post.
- ( ) Install black caps on the B+ and P post.
- ( ) Install the four rubber feet on the bottom of the cabinet.
- ( ) Install the handle using the two #10 sheet metal screws.

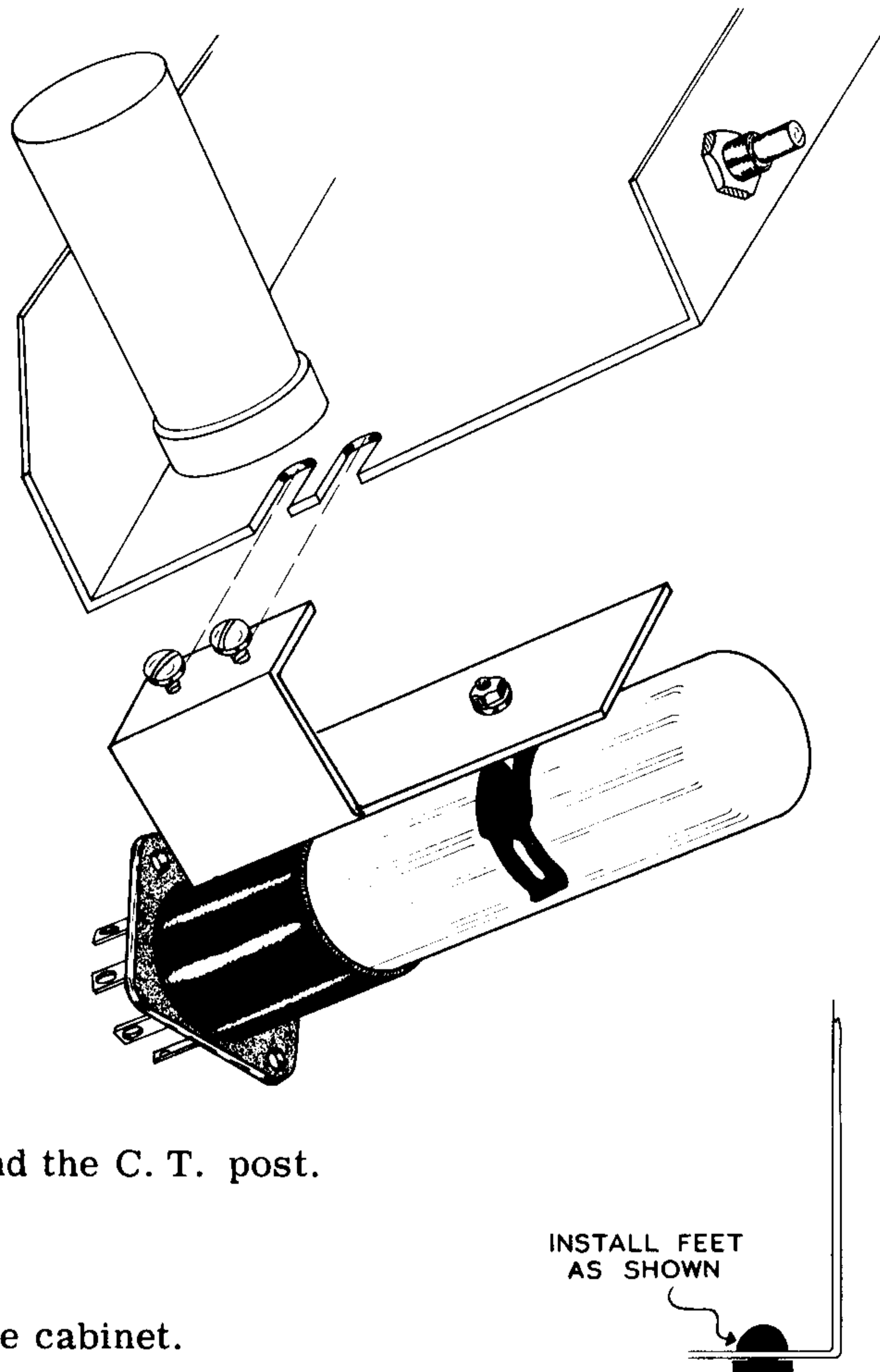

Before installing the instrument in the cabinet, using 6-32 screws, these preliminary tests should be performed. Turn on the instrument and advance the level control. Turn the speaker switch on and the noise switch off. After a few seconds the 1629 eye tube should light green, thus indicating that the B+ and filament circuits are functioning properly. The shadow position of the tube may be adjusted in the panel by rotating the tube. A loud hum should be heard when the probe tip is touched with the hand.

#### IN CASE OF DIFFICULTY

If the T-4 failed to operate in the preliminary test, again check over all connections for unsoldered or poor joints. Using the pictorial diagrams, trace each lead with a red pencil to make sure each one is connected properly. Make sure that no component leads are shorted to each other or to the chassis. Trace through the instrument by touching the grid (pin 2) of the 12CA5 output tube with a screwdriver that is held in contact with your finger. A low level hum should be heard. Move the screwdriver to the grid of the 12AX7 tube section B (pin 2) and then to the grid of section A (pin 7). The hum or noise should become louder with each stage. If no sound is heard, look for trouble in that particular stage. **CAUTION:** To avoid any shock hazard when making the above test, make sure that only the pins that are mentioned in the text are touched with the screwdriver, and the other hand or any other part of the body is not in contact with the chassis or any other conductor that may provide a return path to ground.

If after careful checks the trouble is still not located, check voltage and resistance readings found on the schematic diagram. Note: All voltage and resistance readings were taken with a Heathkit Model V-7A Vacuum Tube Volt Meter. Voltage and resistance readings may vary 20% due to line voltage variations and the tolerance of components. A reading that is off more than 20% would indicate probable trouble in that particular stage. A review of the circuit description may also prove helpful in indicating where to look for the trouble.

#### SERVICE

In event continued operational difficulties of the completed instrument are experienced, the facilities of the Heath Company Service Department are at your disposal. Your instrument may be returned for inspection and repair for a service charge of \$4.00 plus the price of any additional material that may be required. **THIS SERVICE POLICY APPLIES ONLY TO COMPLETED INSTRUMENTS CONSTRUCTED IN ACCORDANCE WITH THE INSTRUCTIONS AS STATED IN THE MANUAL.** Instruments that are not entirely completed or instruments that are modified in design will not be accepted for repair. Instruments showing evidence of acid core solder or paste fluxes will be returned not repaired.

The Heath Company is willing to offer its full cooperation to assist you in obtaining the specified performance level in your instrument. Factory repair service is available for a period of one year from the date of purchase or you may contact the Engineering Consultation Department by mail. For information regarding possible modification of existing kits, it is suggested that you refer to any one or more of the many publications that are available on all phases of electronics. They can be obtained at or through your local library, as well as at any electronic outlet store. Although the Heath Company sincerely welcomes all comments and suggestions, it would be impossible to design, test, evaluate and assume responsibility for proposed circuit changes for specific purposes. Therefore, such modifications must be made at the discretion of the kit builder according to information which will be much more readily available from some local source.

#### SHIPPING INSTRUCTIONS

Before returning a unit for service, be sure that all parts are securely mounted.

**ATTACH A TAG TO THE INSTRUMENT GIVING  
NAME, ADDRESS AND TROUBLE EXPERIENCED.**

Pack in a rugged container, preferably wood, using at least three inches of shredded newspaper or excelsior on all sides. **DO NOT SHIP IN THE ORIGINAL KIT CARTON AS THIS CARTON IS NOT CONSIDERED ADEQUATE FOR SAFE SHIPMENT OF THE COMPLETED INSTRUMENT.** Ship by prepaid express if possible. Return shipment will be made by express collect. Note that a carrier cannot be held liable for damage in transit if packing, in HIS OPINION, is insufficient.

#### SPECIFICATIONS

All prices are subject to change without notice. The Heath Company reserves the right to discontinue instruments and to change specifications at any time without incurring any obligation to incorporate new features in instruments previously sold.

## WARRANTY

Heath Company warrants that for a period of three months from the date of shipment, all Heathkit parts shall be free of defects in materials and workmanship under normal use and service and that in fulfillment of any breach of such warranty, Heath Company shall replace such defective parts upon the return of the same to its factory. The foregoing warranty shall apply only to the original buyer, and is and shall be in lieu of all other warranties, whether express or implied and of all other obligations or liabilities on the part of Heath Company and in no event shall Heath Company be liable for any anticipated profits, consequential damages, loss of time or other losses incurred by the buyer in connection with the purchase, assembly or operation of Heathkits or components thereof. No replacement shall be made of parts damaged by the buyer in the course of handling or assembling Heathkit equipment.

NOTE: The foregoing warranty is completely void and we will not replace, repair or service instruments or parts thereof in which acid core solder or paste fluxes have been used.

HEATH COMPANY

### USING THE T-4

The T-4 Signal Tracer is one of the simplest, yet most effective instruments the service technician can use for rapid, accurate trouble-shooting in radio and TV circuits. The tracer is of the untuned type to simplify operation thus holding control manipulation to an absolute minimum.

This instrument features a number of useful applications which will enable the service technician to quickly locate and diagnose the trouble in the circuit under test. Many of the tests will be performed automatically, and will require only a few seconds of the technician's time. It is suggested however, that the user familiarize himself with all phases of the instrument's operation, so that maximum benefit can be realized from the investment in the kit.

The procedures to be followed when using the T-4 are outlined in a general manner only, and do not represent the limits of its applications. Each individual will develop his own procedures and applications by using the instrument.

#### RF Signal Tracing

To use the Model T-4 for RF signal tracing, the probe switch should be in the RF position, the off-on switch and the speaker switch to the ON position, and the noise switch to OFF. The level control should be adjusted as needed. In some cases it may be desirable to turn off the speaker and observe the approximate signal level on the indicator tube. Note: At near maximum settings of the level control a certain amount of hum will be present; this is due to the high sensitivity of the unit and the fact that the input grid has been extended to the probe permitting it to pick up spurious AC fields.

To illustrate the use of this instrument, a typical radio schematic is presented so the test points may be clearly pointed out. Let us assume that the receiver under test has a specific complaint of low volume. Since the receiver is in partial operating condition, it could be turned on and tuned to a familiar station. The volume control should be turned down so that the speaker output will not interfere with the signal tracer results. The flexible ground lead of the probe should be clipped to the B- or ground circuit of the receiver.

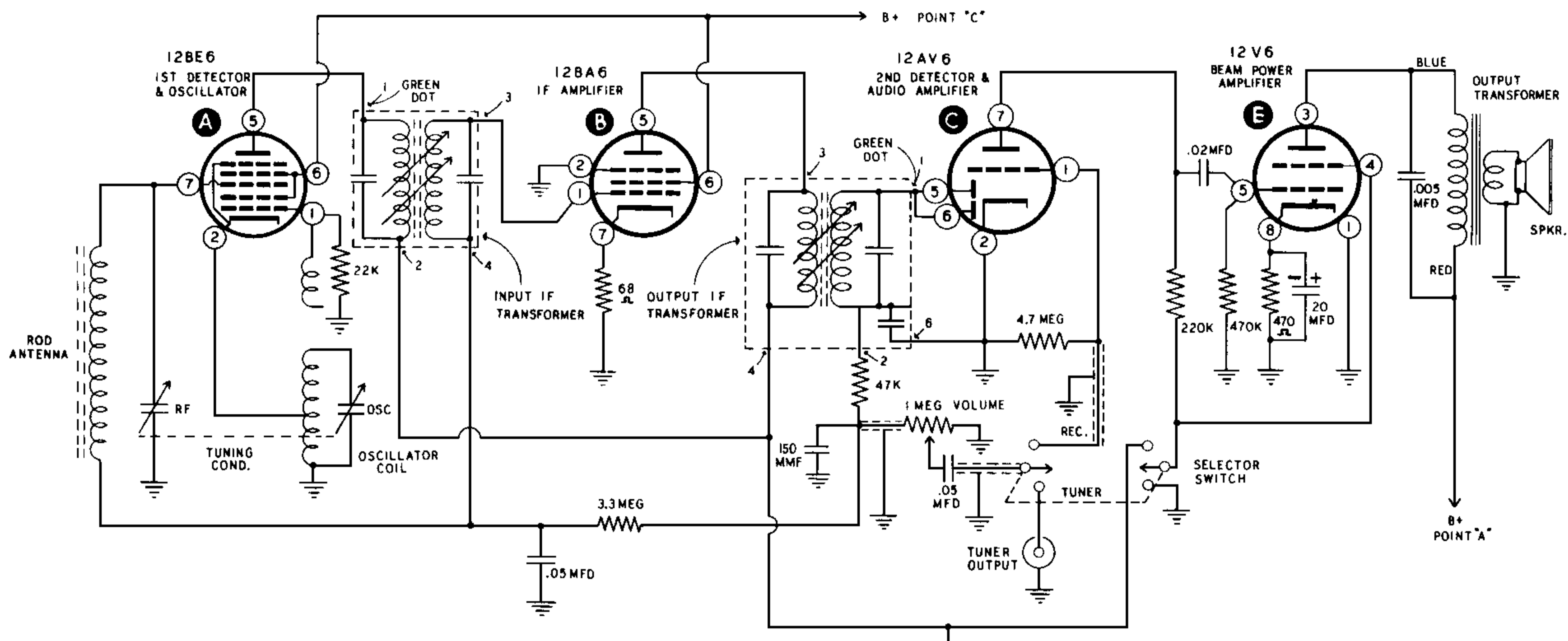

If the receiver is tuned to a strong station, and the probe connected, a signal should be present at the loop antenna, the tuning condenser and at the grid (pin 7) of tube A. When the probe is moved to the plate, (pin 5 of tube A) a substantial increase in signal should be observed. Note: At radiofrequencies, the D. C. voltages used in the IF stages need not be filtered 100%. Coupled with this fact, the signal at the mixer or converter plate (pin 5) is very weak and requires a high gain setting of the tracer. These combined conditions result in the hearing of a high hum level in the tracer when the probe is connected to the plate. On some receivers the hum over-rides the signal making it necessary to move the probe to the secondary of the input IF transformer, (pin 1 of tube B) in order to check the gain of the first stage.

The path of the signal can be traced through any succeeding IF stages to the detector. During these tests an approximate estimation of gain per stage can be made. The amount of gain that can be expected in a circuit can best be determined by previous experience in making similar tests.

In some cases the RF probe causes a slight detuning effect when applied to tuned circuits. In these cases advance the probe to the following test point, and if a good signal is present it would be reasonable to assume that the preceding circuit is functioning properly.

The same general procedure may be used in checking RF and IF stages in FM and TV circuits. Since the actual signal is the prime factor of consideration, the signal tracer will detect the presence or absence of said signal regardless of the type of circuit involved.

### Audio Signal Tracing

After detection has taken place in the receiver, the use of the RF probe is not required and the switch in the probe should be switched to the audio position. Here again the same general conditions previously described apply to the use of the indicator tube and the speaker. From the detector stage (pin 5 and 6 of tube C) the signal can be traced through the various coupling circuits, through the audio and output stage (tube C and E) and the output transformer. These tests can be made quickly and easily and any circuit fault would be indicated by a loss of gain or signal in succeeding stages. Intermittent or faulty volume controls and coupling condensers can also be quickly spotted. When using the tracer keep in mind that the T-4 will detect the presence as well as the absence of signal. For example, it is a common practice to use a high capacity bypass condenser in the cathode circuit of the output tube (pin 8 of tube E). In event the condenser is open there will be a definite indication of a signal at the cathode, whereas a good condenser would by-pass the signal to ground in the desired manner.

As a signal is traced through the audio system the signal level will be extremely high, and it will be necessary to reduce the setting of the signal tracer gain control. A definite reduction in gain will be noted as the probe is moved from the primary to the secondary of the output transformer. This is normal and is due to difference in the turns ratio and impedance of the windings in the transformer.

### Noise Locator

A rather unique and definitely useful application of the T-4 Signal Tracer is its ability to locate noisy and intermittent components in various circuits. Basically the noise locating feature of the signal tracer permits the application of a DC test voltage to any component in the receiver circuit, and the action of the DC voltage in the component is picked up and amplified in the signal tracer itself. This DC voltage of approximately 100 volts is available at the tip of the probe, and of course the ground clip of the probe provides the necessary return circuit. Some precaution should be observed so that the service technician will not encounter a relatively harmless shock hazard. The circuit arrangement is such that even under a dead short circuit condition of ground clip to the test probe, the current drain will not exceed 1 mil and therefore, the possibility of damage to a receiver component is eliminated. To use the T-4 as a noise locator the following conditions should be observed:

First of all it is important that the receiver to be checked should be disconnected entirely from the AC supply line as all tests will be made on an unoperative receiver. The probe switch should be in the audio position for this test, and the panel noise switch to ON. As previously mentioned, a DC voltage in the order of 100 volts is now present between the probe tip and the ground clip.

To illustrate an example of usage, the ground clip should be connected to a B+ supply point in the circuit. The test probe is then applied directly to the plate terminal of an IF tube. The gain control of the signal tracer should be at near maximum position. As the test probe is applied to the plate of the IF tube, a sharp click will be heard in the signal tracer's speaker. A good, clean click will indicate proper circuit continuity and operation. If there is any frying or crackling sounds present, it would be reasonable to assume that some difficulty is being experienced along the circuit, and then the test probe should be moved step-by-step through each portion of the circuit in order that each component may be progressively checked. As the test probe is moved along through coils, resistors and other elements toward the ground clip, it is quite likely that at some point the noise will disappear. When this condition occurs, the preceding step should be repeated and further investigation made of the particular circuit involved for a possible faulty component.

Noisy resistors will very definitely show up as a buzzing or crackling sound. The same condition holds true for a cold or rosin soldered connection in the receiver wiring. Shorted turns in an IF transformer will also be evident by the noise content. The important thing to remember is that a satisfactory component will permit a sharp click to be heard in the speaker, whereas a faulty component will result in a characteristic of an objectionable noise.

Obviously the test voltage can be applied to any component in the receiver. For example, if an audio coupling condenser is suspected, the voltage can be applied across the condenser terminal and then, the condenser lightly jiggled or prodded to determine whether or not a noisy or intermittent condition may be present. Noisy volume controls can be detected, and of course the same condition holds true for the rotor section of variable condensers. Voltage can be applied to the condenser while it is being rotated, and any shorting will be quickly evident. Of course it will be necessary to disconnect any external circuit wiring connected to the condenser terminals. Transformer windings that are faulty will also show up as noise in the signal tracer's speaker. The continuity of the winding can be checked and any leakage from winding to frame can quickly be determined.

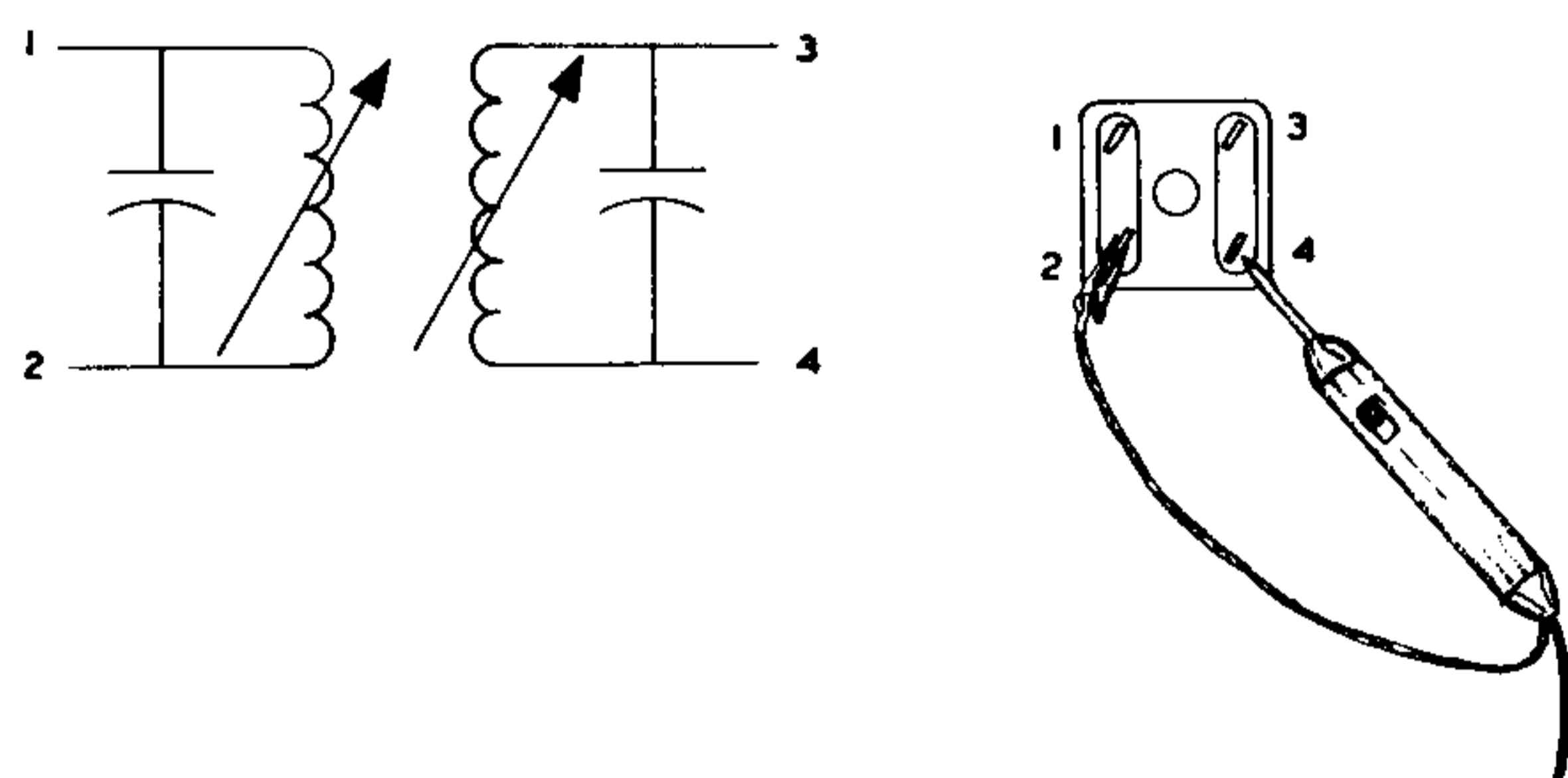

There is practically no limit to the variety of useful applications afforded by this feature of the signal tracer. It is suggested that the service technician further investigate other test procedures where application of a DC voltage to a component in conjunction with a high gain amplifier will permit observation of voltage action.

### Panel Connections

For additional flexibility of operation, the signal tracer panel features five binding posts. These binding posts differ slightly from the conventional type, in the respect that it is possible to insert a banana plug into the top of each jack. They will also accommodate alligator clips, spade lugs and conventional hookup wire. Test leads such as used in the VTVM can be used interchangeably with this instrument when required. The panel arrangement of the T-4 Signal Tracer will permit the utilization of other shop equipment for test procedure. For an example, a VTVM can be connected either from B+ to plate or from plate to common ground terminal. The VTVM will of course be switched to the AC position and the calibrated scale of the meter could be read directly for precise measurements during alignment procedures and gain calculation. The output transformer secondary connections should be utilized if the test requirements required the elimination of the DC voltage present in the primary circuit. A reduction in gain indication should be expected.

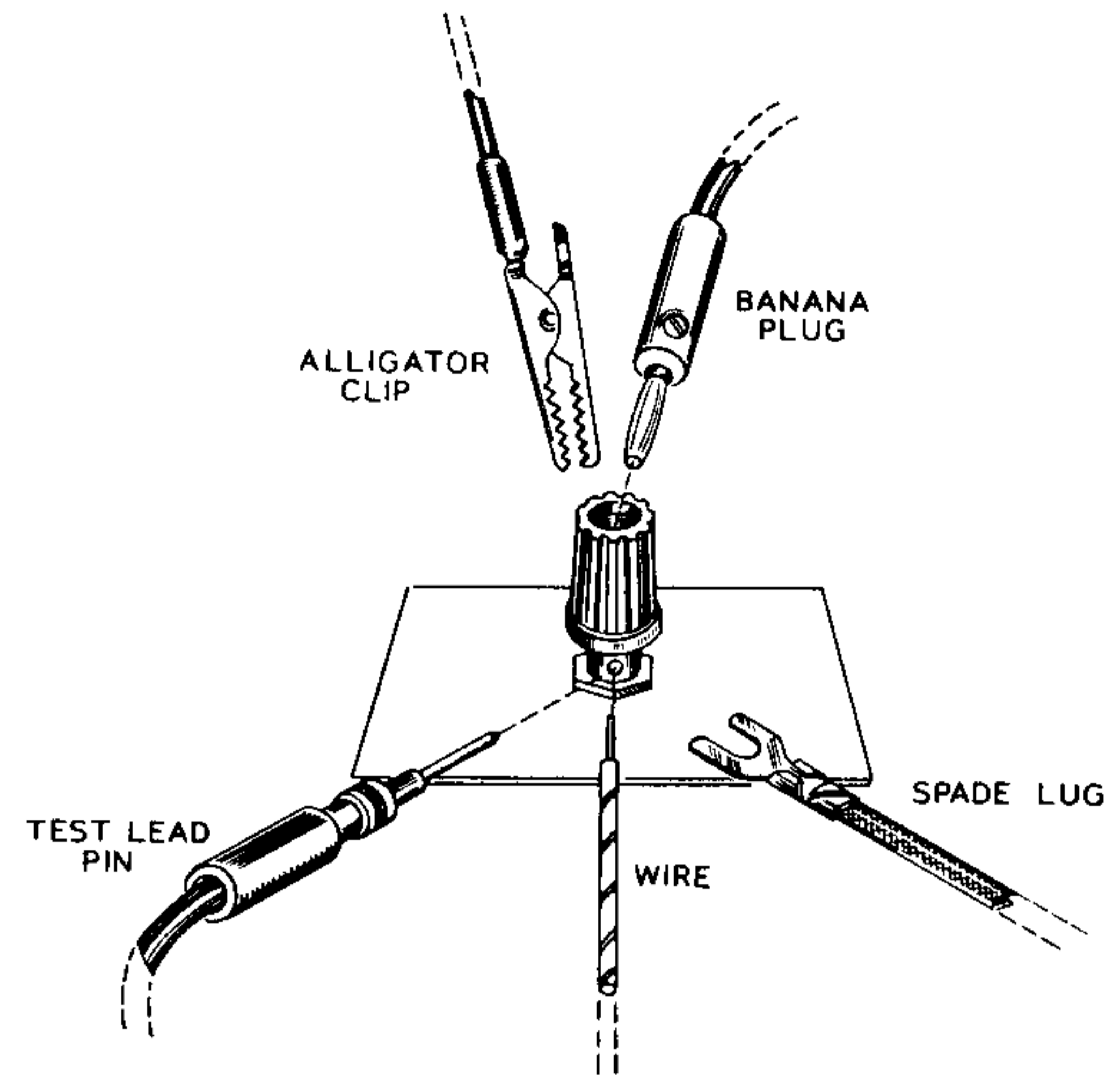

### Test Speaker

In service work it is frequently necessary to remove the chassis of a radio or TV receiver to the repair shop in order to properly complete repair work. In many instances the speaker is a separate piece of equipment, and in some cases it is installed in a rather inaccessible cabinet location. With the Model T-4 Signal Tracer at your disposal, it is not necessary to remove the speaker in view of the fact that the output transformer and speaker are available as test or substitution units. In the majority of cases, the original receiver circuit requirements specify the use of a permanent magnet type speaker and therefore, the substitution can be readily made. The advantage of this feature of the signal tracer is readily apparent when consideration is given to the time and effort conserved by eliminating the necessity for speaker removal and reinstallation on every service job. In addition, the possibility of damage to the speaker cone during the handling process is eliminated.

### Audio System

Quite frequently the service technician will be called upon to service automatic record-changers or phono mechanism. Of course this equipment is usually removed from the cabinet of the receiver and transported to the service shop. On making mechanical repairs or adjustments on the changer mechanism, it is frequently desirable that the output of the phono cartridge be checked and actual conditions of tone reproduction simulated. Here again, it is a relatively simple matter to connect the audio input of the T-4 to the output cable of the record changer. The changer output as heard in the speaker of the tracer will permit detection of any irregularity in mechanical operation, such as turn-table wow or thump, or any objectional noise that could be transmitted through the phono cartridge and reproduced as an undesirable condition.

This same procedure could be used in checking microphones and musical instrument pickups, and here again the results obtained are interpreted on the basis of comparison made with previous tests on similar equipment. The signal tracer can be used in checking FM tuners or other equipment requiring the use of an audio system.

### Output Level Indicator

The Model T-4 Signal Tracer can be used as a level indicator merely by connecting the audio probe to some point in the audio system of a receiver and regulating the amount of gain to permit useable action of the eye indicator. While performing alignment adjustments, the amount of gain or loss experienced in following a specific alignment procedure can quickly be determined by observing the indicator tube. The Heathkit Model T-4 Signal Tracer will prove itself an extremely useful and versatile addition to any service shop. It is earnestly suggested that the user thoroughly familiarize himself with all phases of its operations, so that he may obtain maximum benefit from his investment in this instrument.

### BIBLIOGRAPHY

Rider, John F. ; Servicing by Signal Tracing.  
Ghirardi and Johnson; Radio and TV Receiver Troubleshooting and Repair.

<u>PART No.</u>	<u>PARTS Per Kit</u>	<u>DESCRIPTION</u>
<b>Resistors</b>		
1-4	1	330 ohm 1/2 w. resistor (orange-orange-brown)
1-9	1	1 K ohm 1/2 w. resistor (brown-black-red)
1-20	1	10 K ohm 1/2 w. resistor (brown-black-orange)
1-25	1	47 K ohm 1/2 w. resistor (yellow-violet-orange)
1-31	4	330 K ohm 1/2 w. resistor (orange-orange-yellow)
1-35	1	1 megohm 1/2 w. resistor (brown-black-green)
1-38	1	3.3 megohm 1/2 w. resistor (orange-orange-green)
1-60	2	68 K ohm 1/2 w. resistor (blue-grey-orange)

<b>Condensers</b>		
21-14	3	.001 ceramic condenser
21-27	3	.005 ceramic condenser
23-34	1	.01 tubular condenser 400 v.
25-65	1	50/50 - 150 v. + 20 - 25 v. 3 lug twist prong condenser

<b>Tubes-Diodes-Rectifiers</b>		
56-4	1	Crystal diode
57-13	1	Selenium rectifier 50 MA
411-26	1	12AX7 tube
411-30	1	1629 tube
411-111	1	12CA5 tube

<b>Terminal Strips-Sockets-Binding Posts</b>		
75-17	10	Insulator bushing
75-22	1	Terminal board
427-2	5	Binding post base
431-2	1	2 lug terminal strip
431-10	1	3 lug terminal strip
431-16	1	2 lug terminal strip
434-15	1	7 pin wafer tube socket
434-31	1	8 pin octal tube socket
434-77	1	9 pin wafer tube socket with center ground
100-M16B	2	Binding post cap, black
100-M16R	3	Binding post cap, red

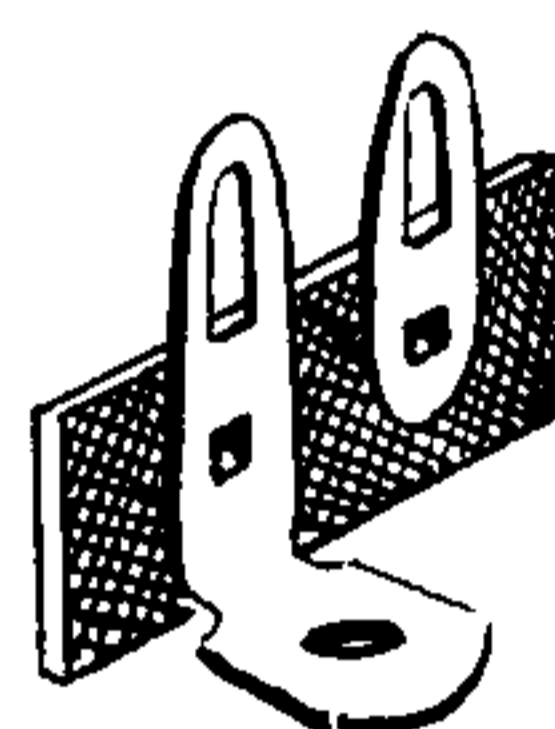

431-16

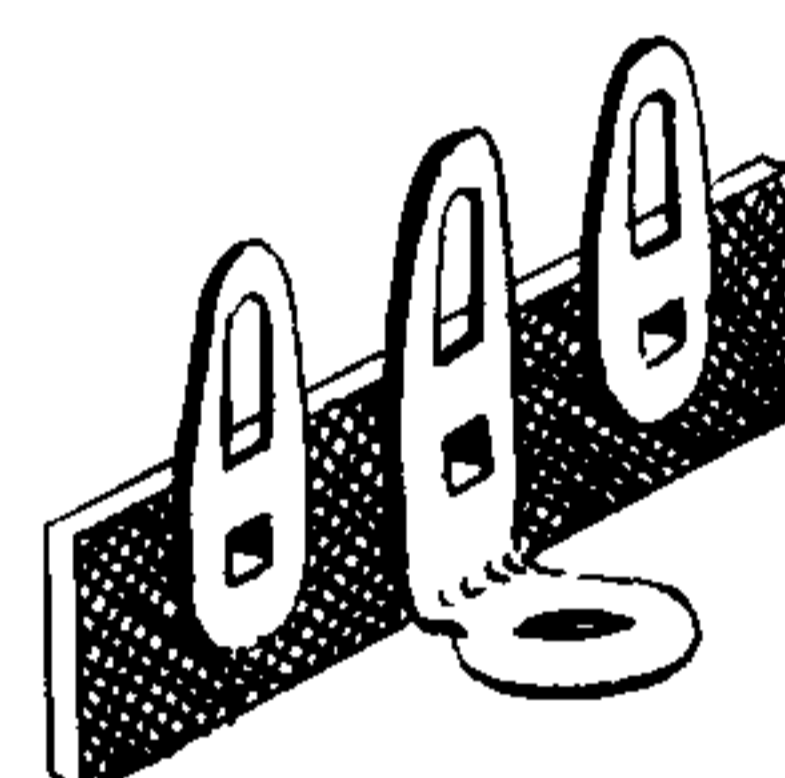

431-10

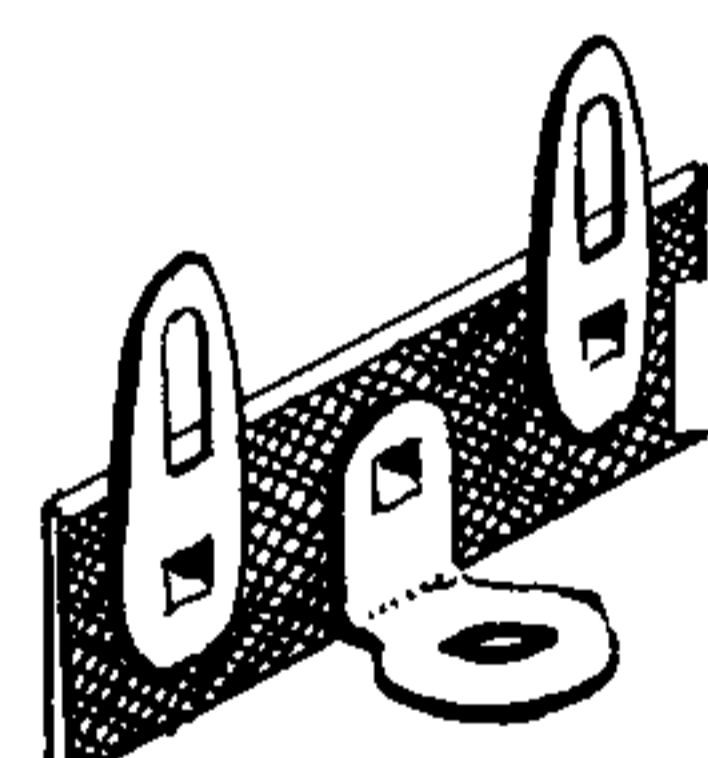

431-2

<b>Wire-Sleeving</b>		
89-1	1	AC line cord
340-2	1	Length bare wire
341-1	1	Length black test lead
341-2	1	Length red test lead
343-2	1	Length RG58U Coax.
344-1	1	Length hookup wire
345-1	1	Length braid
346-1	1	Length 1/16 sleeving
347-1	1	Length 8 wire cable

<b>Controls-Switches</b>		
10-67	1	1 meg control
60-1	2	SPST slide switch
60-7	1	SPDT slide switch small button
63-145	1	2 position rotary switch 1 wafer

<u>PART</u> <u>No.</u>	<u>PARTS</u> <u>Per Kit</u>	<u>DESCRIPTION</u>
<b>Cabinet-Chassis-Speaker</b>		
90-26	1	Cabinet, aluminum
209-10	1	Speaker grill
211-4	1	Handle
401-21	1	3 1/2" speaker
200-M150	1	Chassis
203-143 F188	1	Front panel
204-M150	1	Tube mounting bracket
<b>Hardware</b>		
208-2	1	Spring clip
250-1	4	2-56 self tapping screw
250-2	4	3-48 x 5/16 RHMS
250-8	2	#6 sheet metal screw
250-18	2	8-32 RHMS
250-25	2	4-40 x 5/32 small BHMS
250-31	1	6-32 short RHMS
250-83	2	#10 sheet metal screw
250-89	16	6-32 x 3/8 BHMS
252-1	4	3-48 nut
252-3	21	6-32 nut
252-4	2	8-32 nut
252-7	2	3-8 control nut
252-22	2	Speed nut
253-10	2	Nickel control washer
253-27	4	5-32 flat washer
254-1	16	#6 lockwasher
254-2	2	#8 lockwasher
254-4	1	3/8 control lockwasher
259-1	6	Solder lug
259-10	2	Control solder lug
438-13	2	Banana plug
477-3	1	Solderless phone tip
481-2	1	Condenser mounting wafer 3 prong
<b>Miscellaneous</b>		
51-31	1	Transformer, output
54-64	1	Transformer, power
70-5	1	Black nylon sleeve
70-6	1	Red nylon sleeve
73-1	2	3/8 grommet
260-1	3	Alligator clip
261-1	4	Rubber feet
390-40	1	Label
462-19	2	Skirted knob
476-11	1	Probe body for switch
595-189	1	Manual
459-M2	1	Red probe end
459-M3	1	Black probe end

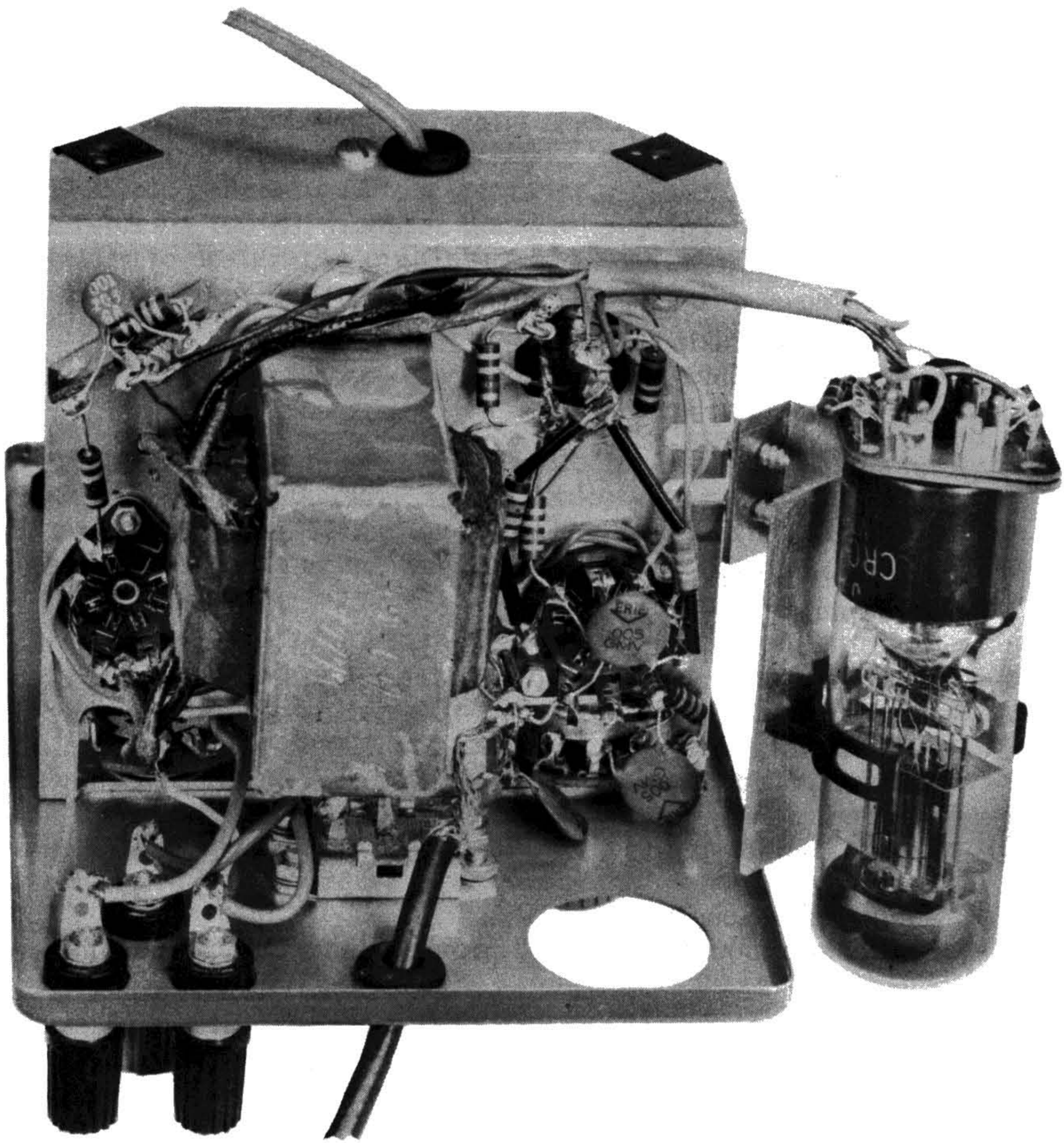

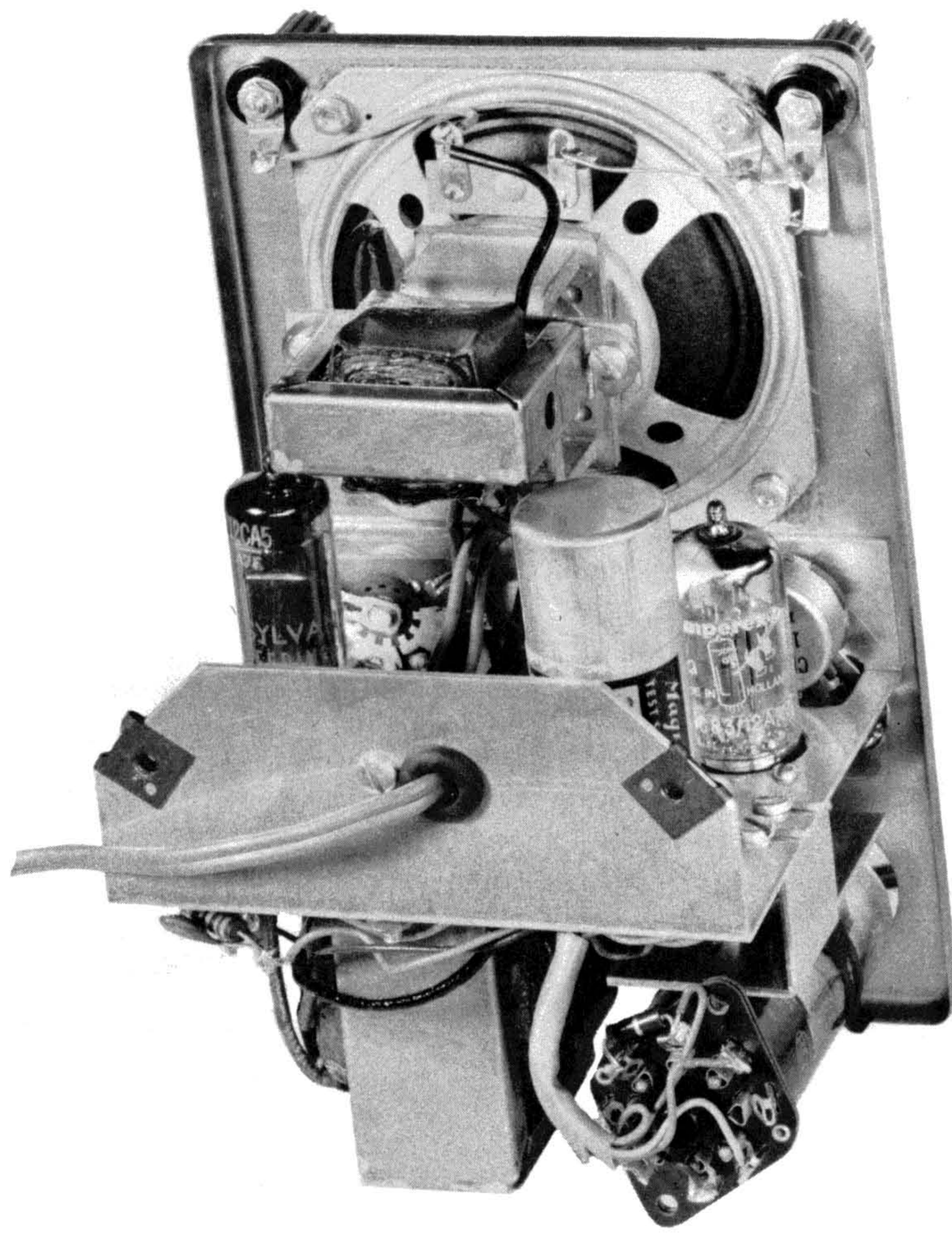

## HELPFUL KIT BUILDING INFORMATION

Before attempting actual kit construction read the construction manual through thoroughly to familiarize yourself with the general procedure. Note the relative location of pictorials and pictorial inserts in respect to the progress of the assembly procedure outlined.

This information is offered primarily for the convenience of novice kit builders and will be of definite assistance to those lacking thorough knowledge of good construction practices. Even the advanced electronics enthusiast may benefit by a brief review of this material before proceeding with kit construction. In the majority of cases, failure to observe basic instruction fundamentals is responsible for inability to obtain desired level of performance.

### RECOMMENDED TOOLS

The successful construction of Heathkits does not require the use of specialized equipment and only basic tools are required. A good quality electric soldering iron is essential. The preferred size would be a 100 watt iron with a small tip. The use of long nose pliers and diagonal or side cutting pliers is recommended. A small screw driver will prove adequate and several additional assorted screw drivers will be helpful. Be sure to obtain a good supply of rosin core type radio solder. Never use separate fluxes, paste or acid solder in electronic work.

### ASSEMBLY

In the actual mechanical assembly of components to the chassis and panel, it is important that the procedure shown in the manual be carefully followed. Make sure that tube sockets are properly mounted in respect to keyway or pin numbering location. The same applies to transformer mountings so that the correct transformer color coded wires will be available at the proper chassis opening.

Make it a standard practice to use lock washers under all 6-32 and 8-32 nuts. The only exception being in the use of solder lugs—the necessary locking feature is already incorporated in the design of the solder lugs. A control lock washer should always be used between the control and the chassis to prevent undesirable rotation in the panel. To improve instrument appearance and to prevent possible panel marring use a control flat nickel washer under each control nut.

When installing binding posts that require the use of fiber insulating washers, it is good practice to slip the shoulder washer over the binding post mounting stud before installing the mounting stud in the panel hole provided. Next, install a flat fiber washer and a solder lug under the mounting nut. Be sure that the shoulder washer is properly centered in the panel to prevent possible shorting of the binding post.

### WIRING

When following wiring procedure make the leads as short and direct as possible. In filament wiring requiring the use of a twisted pair of wires allow sufficient slack in the wiring that will permit the twisted pair to be pushed against the chassis as closely as possible thereby affording relative isolation from adjacent parts and wiring.













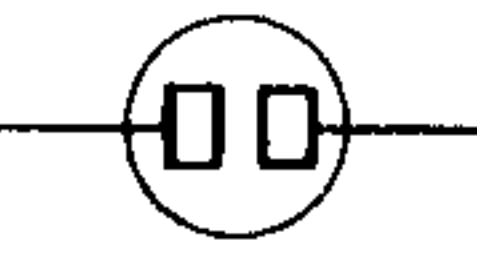



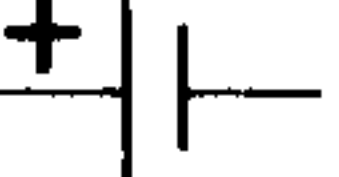
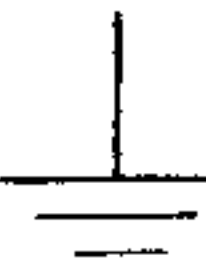



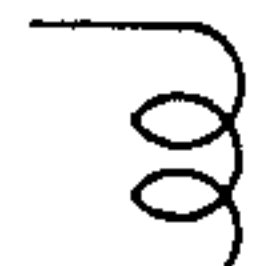
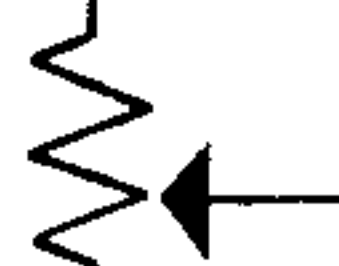
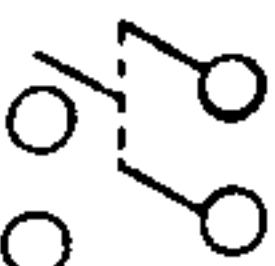



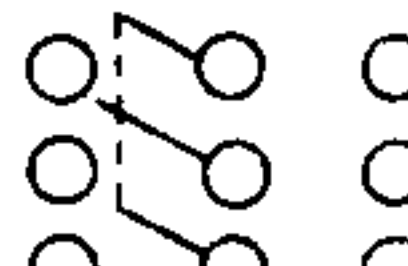

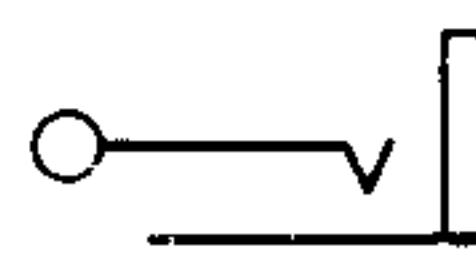
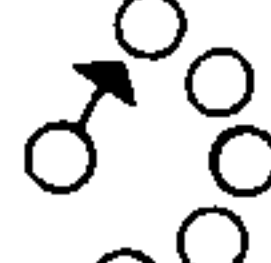

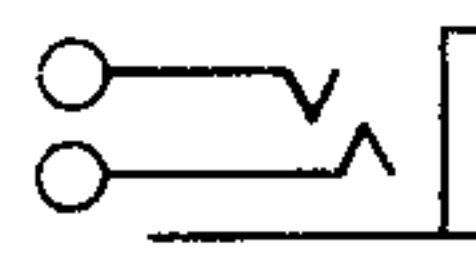
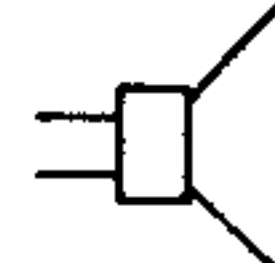

When removing insulation from the end of hookup wire, it is seldom necessary to expose more than a quarter inch of the wire. Excessive insulation removal may cause a short circuit condition in respect to nearby wiring or terminals. In some instances, transformer leads of solid copper will have a brown baked enamel coating. After the transformer leads have been trimmed to a suitable length, it is necessary to scrape the enamel coating in order to expose the bright copper wire before making a terminal or soldered connection.

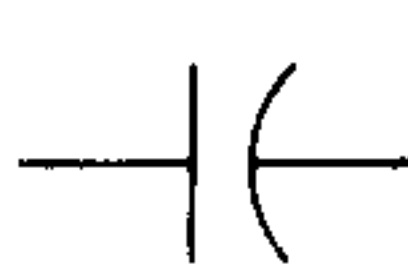
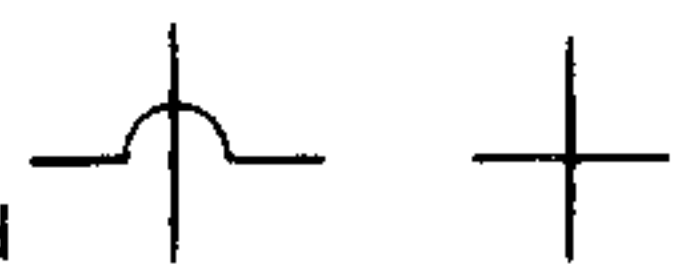
In mounting parts such as resistors or condensers, trim off all excess lead lengths so that the parts may be installed in a direct point-to-point manner. When necessary use spaghetti or insulated sleeving over exposed wires that might short to nearby wiring.

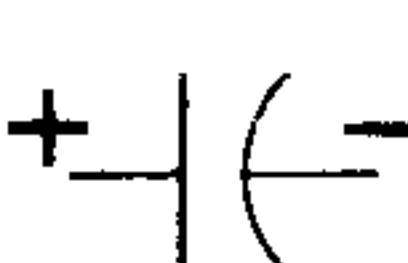
It is urgently recommended that the wiring dress and parts layout as shown in the construction manual be faithfully followed. In every instance, the desirability of this arrangement was carefully determined through the construction of a series of laboratory models.

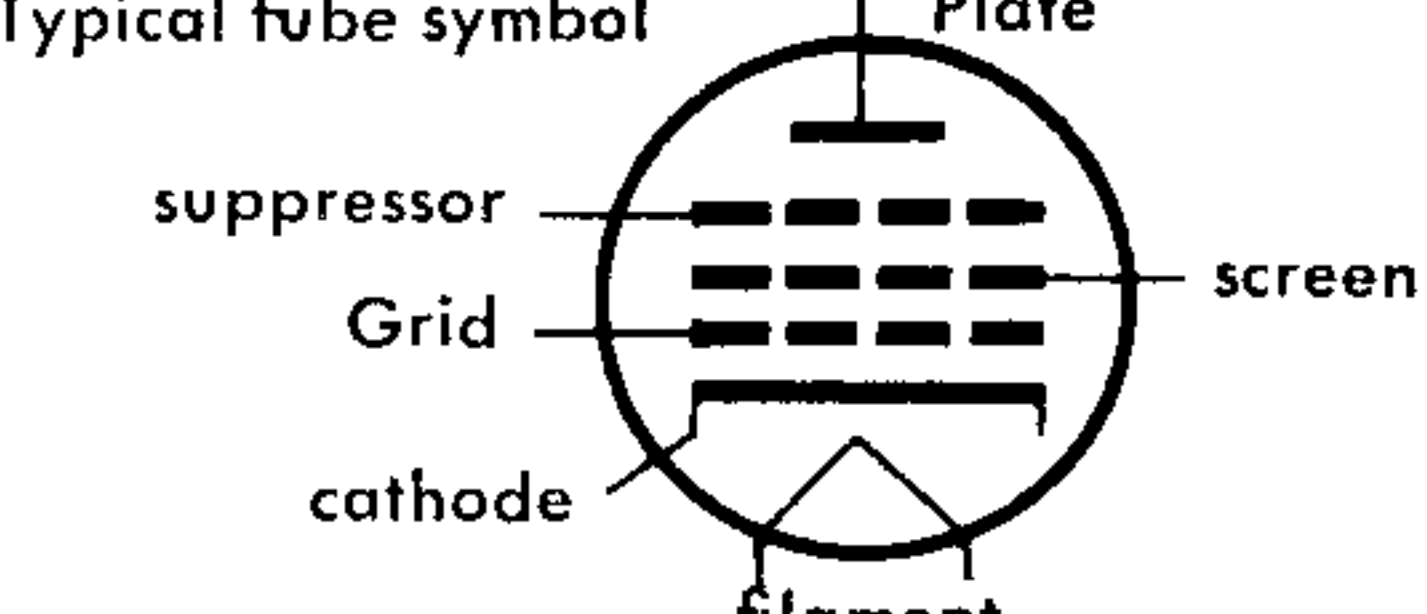
### SOLDERING

Much of the performance of the kit instrument, particularly in respect to accuracy and stability, depends upon the degree of workmanship used in making soldered connections. Proper soldered connections are not at all difficult to make but it would be advisable to observe a few precautions. First of all before a connection is to be soldered, the connection itself should be clean and mechanically strong. Do not depend on solder alone to hold a connection together. The tip of the soldering iron should be bright, clean and free of excess solder. Use enough heat to thoroughly flow the solder smoothly into the joint. Avoid excessive use of solder and do not allow a flux flooding condition to occur which could conceivably cause a leakage path between adjacent terminals on switch assemblies and tube sockets. This is particularly important in instruments such as the VTVM, oscilloscope and generator kits. Excessive heat will also burn or damage the insulating material used in the manufacture of switch assemblies. Be sure to use only good quality rosin core radio type solder.

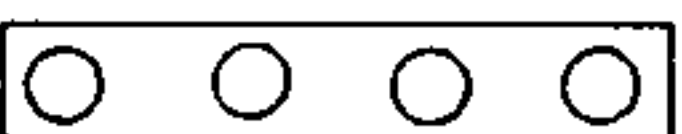
Antenna General		Resistor General		Neon Bulb		Receptacle two-conductor	
Loop		Resistor Tapped		Illuminating Lamp		Battery	
Ground		Resistor Variable		Switch Single pole Single throw		Fuse	
Inductor General		Potentiometer		Switch double pole single throw		Piezoelectric Crystal	
Air core Transformer General		Thermistor		Switch Triple pole Double throw		1000 =	<b>K</b>
Adjustable Powdered Iron Core		Jack two conductor		Switch Multipoint or Rotary		1,000,000 =	<b>M</b>
Magnetic Core Variable Coupling		Jack three conductor		Speaker		OHM =	$\Omega$
Iron Core Transformer		Wires connected		Rectifier		Microfarad =	<b>MF</b>
Capacitor General		Wires Crossing but not connected		Microphone		Micro Microfarad =	<b>MMF</b>
Capacitor Electrolytic		A. Ammeter V. Voltmeter		Typical tube symbol 	Binding post		
Capacitor Variable		G. Galvanometer MA. Milliammeter uA. Microammeter, etc.			Terminal strip		
						Wiring between like letters is	↓ ↓ ↓ ↓ → X Y X Y X
						understood	→ Y

# **HEATH COMPANY**

*A Subsidiary of Daystrom Inc.*

**THE WORLD'S FINEST ELECTRONIC EQUIPMENT IN KIT FORM**

**BENTON HARBOR, MICHIGAN**